



DIPLOMA IN ENGINEERING AND TECHNOLOGY

1020 - 2020 - 3020

DEPARTMENT OF MECHANICAL ENGINEERING
(FULL TIME – PART TIME – SANDWICH)
SEMESTER PATTERN

N – SCHEME

IMPLEMENTED FROM 2020 - 2021

CURRICULUM DEVELOPMENT CENTRE

DIRECTORATE OF TECHNICAL EDUCATION
CHENNAI-600 025, TAMIL NADU

Blank Page

STATE BOARD OF TECHNICAL EDUCATION & TRAINING, TAMILNADU DIPLOMA IN
ENGINEERING / TECHNOLOGY SYLLABUS

N SCHEME

(To be implemented for the students admitted from the 2020 -2021 onwards)

Chairperson

TMT. G.LAXMI PRIYA, I.A.S
Director
Directorate of Technical Education, Guindy, Chennai.

Co-ordinator

Thiru R.Kanagaraj
Principal
Government Polytechnic College, Purasawalkam, Chennai.

**1020 - 2020 - 3020
DIPLOMA IN MECHANICAL ENGINEERING
(FULL TIME – PART TIME – SANDWICH)**

Convener

Thiru R.Kanagaraj M.E.,
Principal
Government Polytechnic College, Purasawalkam, Chennai.

Members

Thiru M.Sugumaran, M.E.,
Principal I/c
Ramakrishna Mission Polytechnic
College
Mylapore, Chennai – 4.

Dr. N.Thangavelu, M.E., Ph. D.,
HOD- Mechanical Engineering
Sakthi Polytechnic College
Sakthinagar,

Dr. V.Prabhu Raja, M.E., Ph. D.,
Professor (CAS)
Department of Mechanical Engineering
PSG College of Technology,
Peelamedu

Thiru K.Subaramani, M.E.,
HOD – Mechanical Engineering
NPA Centenary Polytechnic College
Kotagiri

Thiru T.E.Kuppuswamy
Asst.General Manager- Tool Room
Mudhra Fine Blanc(p) Ltd.
Chennai

Dr. V.V.Senthil Kumar M.E., Ph.D.,
Principal
TVS Polytechnic College
Chennai.

Thiru M.Saravanan B.Tech
Manager HR training
Delphi TVS Technologies Ltd.
Uragadam, Chennai

Dr. N.Rajamanickam M.E., Ph.D.,
Programmer CDC
Directorate of technical Education
Chennai

Thiru R.Karthikeyan M.E.,
HOD Mechanical Engineering
PACR Polytechnic College
Rajapalayam.

Blank Page

**DIPLOMA COURSES IN ENGINEERING/TECHNOLOGY
(SEMESTER SYSTEM)**

(Implemented from 2020 - 2021)

N – SCHEME

REGULATIONS*

**Applicable to the Diploma Courses other than Diploma in Hotel Management & Catering Technology.*

1. Description of the Course:

a. Full Time (3 years)

The Course for the Full Time Diploma in Engineering shall extend over a period of three academic years, consisting of 6 semesters* and the First Year is common to all Engineering Branches.

b. Sandwich (3½ years)

The Course for the Sandwich Diploma in Engineering shall extend over a period of three and half academic years, consisting of 7 semesters* and the First Year is common to all Engineering Branches. The subjects of three years full time diploma course being regrouped for academic convenience.

During 4th and/or during 7th semester the students undergo industrial training for six months/ one year. Industrial training examination will be conducted after completion of every 6 months of industrial training.

c. Part Time (4 years)

The course for the Part Time Diploma in Engineering shall extend over a period of 4 academic years containing of 8 semesters*, the subjects of 3 year full time diploma courses being regrouped for academic convenience.

*** Each Semester will have 16 weeks duration of study with 35 hrs. / Week for Regular Diploma Course and 18 hrs. / Week for Part-Time Diploma Course.**

The Curriculum for all the 6 Semesters of Diploma courses (Engineering & Special Diploma Courses viz. Textile Technology, Leather Technology, Printing Technology, Chemical Technology etc.) have been revised and revised curriculum is applicable for the candidates admitted from 2020 – 2021 academic year onwards.

2. Condition for Admission:

Condition for admission to the Diploma courses shall be required to have passed in The S.S.L.C Examination of the Board of Secondary Education, Tamil Nadu.(Or)

The Anglo Indian High School Examination with eligibility for Higher Secondary Course in Tamil Nadu.(Or)

The Matriculation Examination of Tamil Nadu.(Or)

Any other Examinations recognized as equivalent to the above by the Board of Secondary Education, Tamil Nadu.

Note: In addition, at the time of admission the candidate will have to satisfy certain minimum requirements, which may be prescribed from time to time.

3. Admission to Second year (Lateral Entry):

A pass in HSC (academic) or (vocational) courses mentioned in the Higher Secondary Schools in Tamil Nadu affiliated to the Tamil Nadu Higher Secondary Board with eligibility for university Courses of study or equivalent examination & Should have studied the following subjects.

A pass in 2 Years ITI with appropriate Trade or Equivalent examination.

Sl. No	Courses	H.Sc Academic	H.Sc Vocational		Industrial Training Institutes Courses
		Subjects Studied	Subjects Studied		
			Related subjects	Vocational subjects	
1.	All the Regular and Sandwich Diploma Courses	Physics and Chemistry as compulsory along with Mathematics / Biology	Maths / Physics / Chemistry	Related Vocational Subjects Theory & Practical	2 years course to be passed with appropriate Trade
2.	Diploma Course in Commercial Practice	English & Accountancy English & Elements of Economics English & Elements of Commerce	English & Accountancy, English & Elements of Economics, English & Management Principles & Techniques, English & Typewriting	Accountancy & Auditing, Banking, Business Management, Co-operative Management, International Trade, Marketing & Salesmanship, Insurance & Material Management, Office Secretaryship	

- For the Diploma Courses related with Engineering/Technology, the related / equivalent subjects prescribed along with Practicals may also be taken for arriving the eligibility.
- Branch will be allotted according to merit through counseling by the respective Principal as per communal reservation.
- For admission to the Textile Technology, Leather Technology, Printing Technology, Chemical Technology and Commercial Practice Diploma courses the candidates studied the related subjects will be given first preference.
- *Candidates who have studied Commerce Subjects are not eligible for Engineering Diploma Courses.*

4. Age Limit: No Age limit.

5. Medium of Instruction: English

6. Eligibility for the Award of Diploma:

No candidate shall be eligible for the Diploma unless he/she has undergone the prescribed course of study for a period of not less than 3 academic years in any institution affiliated to the State Board of Technical Education and Training, Tamil Nadu, when joined in First Year and two years if joined under Lateral Entry scheme in the second year and passed the prescribed examination.

The minimum and maximum period for completion of Diploma Courses are as given below:

Diploma Course	Minimum Period	Maximum Period
Full Time	3 Years	6 Years
Full Time (Lateral Entry)	2 Years	5 Years
Sandwich	3½ Years	6½ Years
Part Time	4 Years	7 Years

This will come into effect from N Scheme onwards i.e. from the academic year 2020-2021.

7. Subjects of Study and Curriculum outline:

The subjects of study shall be in accordance with the syllabus prescribed from time to time, both in theory and practical subjects.

The curriculum outline is given in Annexure – I.

8. Examinations:

Board Examinations in all subjects of all the semesters under the scheme of examinations will be conducted at the end of each semester.

The internal assessment marks for all the subjects will be awarded on the basis of continuous internal assessment earned during the semester concerned. For each subject 25 marks are allotted for internal assessment. Board Examinations are conducted for 100 marks and reduced to 75.

The total marks for result are $75 + 25 = 100$ Marks.

9. Continuous Internal Assessment:

A. For Theory Subjects:

The Internal Assessment marks for a total of 25 marks, which are to be distributed as follows:

i) Subject Attendance

5 Marks

(Award of marks for subject attendance to each subject Theory/Practical will be as per the range given below)

80%	-	83%	1 Mark
84%	-	87%	2 Marks
88%	-	91%	3 Marks
92%	-	95%	4 Marks
96%	-	100%	5 Marks

ii) Test

10 Marks

2 Tests each of 2 hours duration for a total of 50 marks are to be conducted. Average of the these two test marks will be taken and the marks to be reduced to: 05 Marks

The Test – III is to be the Model Examination covering all the five units and the marks obtained will be reduced to: 05 Marks

TEST	UNITS	WHEN TO CONDUCT	MARKS	DURATION
Test I	Unit – I & II	End of 6 th week	50	2 Hrs
Test II	Unit – III & IV	End of 12 th week	50	2 Hrs
Test III	Model Examination: Covering all the 5 Units. (Board Examinations-question paper-pattern).	End of 16 th week	100	3 Hrs

From the Academic Year 2020 – 2021 onwards.

Question Paper Pattern for the Test - I and Test – II is as follows. The tests should be conducted by proper schedule. Retest marks should not be considered for internal assessment.

Without Choice:

Part A Type questions:	6 Questions × 1 mark	06 marks
Part B Type questions:	7 Questions × 2 marks	14 marks
Part C Type questions:	2 Questions × 15 marks	30 marks
	Total	50 marks

iii) Assignment

5 Marks

For each subject Three Assignments are to be given each for 20 marks and the average marks scored should be reduced for 5 marks.

iv) Seminar Presentation

5 Marks

The students have to select the topics either from their subjects or general subjects which will help to improve their grasping capacity as well as their capacity to express the subject in hand. The students will be allowed to prepare the material for the given topic using the library hour and they will be permitted to present seminar (For First and Second Year, the students will be permitted to present the seminar as a group not exceeding six members and each member of the group should participate in the presentation. For the Third Year, the students should present the seminar

individually.) The seminar presentation is mandatory for all theory subjects and carries 5 marks for each theory subject. The respective subject faculty may suggest topics to the students and will evaluate the submitted materials and seminar presentation. (2 ½ marks for the material submitted in writing and 2 ½ marks for the seminar presentation). For each subject minimum of two seminars are to be given and the average marks scored should be reduced to 5 marks.

All Test Papers, Assignment Papers / Notebooks and the seminar presentation written material after getting the signature with date from the students must be kept in safe custody in the department for verification and audit. It should be preserved for one semester after publication of Board Exam results and produced to the flying squad and the inspection team at the time of inspection/verification.

B. For Practical Subjects:

The Internal Assessment mark for a total of 25 marks which are to be distributed as follows:-

a) Attendance	: 5 Marks
(Award of marks same as theory subjects)	
b) Procedure/ observation and tabulation/ Other Practical related Work	: 10 Marks
c) Record writing	: 10 Marks
TOTAL	: 25 Marks

- *All the Experiments/Exercises indicated in the syllabus should be completed and the same to be given for final Board examinations.*
- The observation note book / manual should be maintained for 10 marks. The observation note book / manual with sketches, circuits, programme, reading and calculation written by the students manually depends upon the practical subject during practical classes should be evaluated properly during the practical class hours with date.
- The Record work for every completed exercise should be submitted in the subsequent practical classes and marks should be awarded for 10 marks for each exercise as per the above allocation.
- At the end of the Semester, the average marks of all the exercises should be calculated for 20 marks (including Observation and Record writing) and the marks

awarded for attendance is to be added to arrive at the internal assessment mark for Practical. (20+5=25 marks)

- Only regular students, appearing first time have to submit the duly signed bonafide record note book/file during the Practical Board Examinations.

All the marks awarded for Assignments, Tests, Seminar presentation and Attendance should be entered periodically in the Personal Theory Log Book of the staff, who is handling the theory subject.

The marks awarded for Observation, Record work and Attendance should be entered periodically in the Personal Practical Log Book of the staff, who is handling the practical subject.

10. Communication Skill Practical, Computer Application Practical and Physical Education:

The Communication Skill Practical and Computer Application Practical with more emphasis are being introduced in First Year. Much Stress is given to increase the Communication skill and ICT skill of students.

As per the recommendation of MHRD and under Fit India scheme, the Physical education is introduced to encourage students to remain healthy and fit by including physical activities and sports.

11. Project Work and Internship:

The students of all the Diploma Courses have to do a Project Work as part of the Curriculum and in partial fulfillment for the award of Diploma by the State Board of Technical Education and Training, Tamil Nadu. In order to encourage students to do worthwhile and innovative projects, every year prizes are awarded for the best three projects i.e. institution wise, region wise and state wise. **The Project work must be reviewed twice in the same semester. The project work is approved during the V semester by the properly constituted committee with guidelines.**

a) Internal assessment mark for Project Work & Internship:

Project Review I	...	10 marks
Project Review II	...	10 marks
Attendance	...	05 marks (Award of marks same as theory subject pattern)

Total	...	25 marks
-------	-----	-----------------

Proper record should be maintained for the two Project Reviews and preserved for one semester after the publication of Board Exams results. It should be produced to the flying squad and the inspection team at the time of inspection/verification.

b) Allocation of Marks for Project Work & Internship in Board Examinations:

Demonstration/Presentation	25 marks
Report	25 marks
Viva Voce	30 marks
Internship Report	20 marks

Total	100* marks
--------------	-------------------

*Examination will be conducted for 100 marks and will be converted to 75 marks.

c) Internship Report:

The internship training for a period of two weeks shall be undergone by every candidate at the end of IV / V semester during vacation. The certificate shall be produced along with the internship report for evaluation. The evaluation of internship training shall be done along with final year “Project Work & Internship” for 20 marks. The internship shall be undertaken in any industry / Government or Private certified agencies which are in social sector / Govt. Skill Centres / Institutions / Schemes.

A neatly prepared PROJECT REPORT as per the format has to be submitted by individual student during the Project Work & Internship Board examination.

12. Scheme of Examinations:

The Scheme of examinations for subjects is given in Annexure - II.

13. Criteria for Pass:

1. No candidate shall be eligible for the award of Diploma unless he/she has undergone the prescribed course of study successfully in an institution approved by AICTE and affiliated to the State Board of Technical Education & Training, Tamil Nadu and pass all the subjects prescribed in the curriculum.
2. A candidate shall be declared to have passed the examination in a subject if he/she secures not less than *40% in theory subjects* and *50% in practical subjects* out of the total prescribed maximum marks including both the Internal Assessment and the Board Examinations marks put together, subject to the condition that he/she secures at least a minimum of *40 marks out of 100 marks in the Board Theory Examinations* and a minimum of *50 marks out of 100 marks in the Board Practical Examinations*.

14. Classification of successful candidates:

Classification of candidates who will pass out the final examinations from April 2023 onwards (Joined first year in 2020 -2021) will be done as specified below.

First Class with Superlative Distinction:

A candidate will be declared to have passed in **First Class with Superlative Distinction** if he/she secures not less than 75% of the marks in all the subjects and passes all the semesters in the first appearance itself and passes all subjects within the stipulated period of study 2 / 3 / 3½ / 4 years [Full Time(lateral entry)/Full Time/Sandwich/Part Time] without any break in study.

First Class with Distinction:

A candidate will be declared to have passed in **First Class with Distinction** if he/she secures not less than 75% of the aggregate marks in all the semesters put together and passes all the semesters except the I and II semester in the first appearance itself and passes all subjects within the stipulated period of study 2 / 3 / 3½ / 4 years [Full time(lateral entry)/Full Time/Sandwich/Part Time] without any break in study.

First Class:

A candidate will be declared to have passed in **First Class** if he/she secures not less than 60% of the aggregate marks in all the semesters put together and passes all the subjects within the stipulated period of study 2 / 3 / 3½ / 4 years [Full time(lateral entry)/Full Time/Sandwich/Part Time] without any break in study.

Second Class:

All other successful candidates will be declared to have passed in **Second Class**.

The above classifications are also applicable for the Sandwich / Part-Time students who pass out Final Examination from October 2023 /April 2024 onwards (both joined First Year in 2020 -2021)

15. Duration of a period in the Class Time Table:

The duration of each period of instruction is 1 hour and the total period of instruction hours excluding interval and lunch break in a day should be uniformly maintained as 7 hours corresponding to 7 periods of instruction (Theory & Practical).



Blank Page

STATE BOARD OF TECHNICAL EDUCATION & TRAINING, TAMILNADU
DIPLOMA IN ENGINEERING / TECHNOLOGY SYLLABUS

N – SCHEME

ANNEXURE – I

CURRICULUM OUTLINE

1020 DIPLOMA IN MECHANICAL ENGINEERING (FULL TIME)

III Semester

Subject Code	SUBJECT	HOURS PER WEEK			
		Theory hours	Drawing hours	Practical hours	Total hours
4020310	Strength of Materials	5	-	-	5
4020320	Manufacturing Technology - I	5	-	-	5
4020330	Measurements and Metrology	5	-	-	5
4020340	Thermal Engineering – I	5	-	-	5
4020350	Machine Drawing and CAD Practical	-	2	2	4
4020360	Manufacturing Technology – I Practical	-	-	4	4
4020370	Measurements and Metrology Practical	-	-	4	4
		20	2	10	32
Extra / Co-Curricular activities					
Library		-	-	-	1
Physical Education		-	-	-	2
TOTAL					35

Blank Page

IV Semester

Subject Code	SUBJECT	HOURS PER WEEK			
		Theory hours	Drawing hours	Practical hours	Total hours
4020410	Fluid Mechanics and Fluid Power	5	-	-	5
4020420	Manufacturing Technology II	5	-	-	5
4020430	Electrical Drives and Controls	5	-	-	5
4020440	Production and Quality Management	5	-	-	5
4020450	Strength of Materials and Fluid Mechanics Practical	-	-	4	4
4020460	Manufacturing Technology II Practical	-	-	4	4
4020470	Electrical Drives and Control Practical	-	-	4	4
		20		12	32
Extra / Co-Curricular activities					
Library		-	-	-	1
Physical Education		-	-	-	2
TOTAL					35

Blank Page

V Semester

Subject Code	SUBJECT	HOURS PER WEEK			
		Theory hours	Drawing hours	Practical hours	Total hours
4020510	Design of Machine Elements	6	-	-	6
4020520	Thermal Engineering – II	5	-	-	5
Elective I Theory					
4020531	Computer Integrated Manufacturing	5	-	-	5
4020532	Green Energy and Energy Conservation	5	-	-	
4020533	Mechatronics	5	-	-	
4020540	Process Automation Practical	-	-	4	4
4020550	Thermal Engineering Practical			4	4
Elective I Practical					
4020561	Computer Integrated Manufacturing Practical	-	-	4	4
4020562	Green Energy and Energy Conservation Practical	-	-	4	
4020563	Mechatronics Practical	-	-	4	
4020570	Entrepreneurship & Startup			4	4
		16	-	16	32
Extra / Co-Curricular activities					
Library		-	-	-	1
Physical Education		-	-	-	2
TOTAL					35

Blank Page

VI Semester

Subject Code	SUBJECT	HOURS PER WEEK			
		Theory hours	Drawing hours	Practical hours	Total hours
4020610	Industrial Engineering and Management	6	-	-	6
4020620	E Vehicle Technology & Policy	4	-	-	4
Elective II Theory					
4020631	Industrial Robotics and 3D Printing	5	-	-	5
4020632	Refrigeration and Air Conditioning	5	-	-	
4020633	Automobile Technology	5	-	-	
4020640	Solid Modelling Practical	-	-	6	6
Elective II Practical					
4020651	Industrial Robotics and 3D Printing Practical	-	-	5	5
4020652	Refrigeration and Air Conditioning Practical	-	-	5	
4020653	Automobile Technology Practical	-	-	5	
4020660	Project Work and Internship	-	-	6	6
		15	-	17	32
Extra / Co-Curricular activities					
Library		-	-	-	1
Physical Education		-	-	-	2
TOTAL					35

Blank Page

ANNEXURE-II

STATE BOARD OF TECHNICAL EDUCATION & TRAINING, TAMILNADU

DIPLOMA IN ENGINEERING / TECHNOLOGY SYLLABUS

N – SCHEME

SCHEME OF EXAMINATION

1020 DIPLOMA IN MECHANICAL ENGINEERING (FULL TIME)

III Semester

Subject Code	SUBJECT	Marks			Minimum marks for pass	Duration of ExamHours
		Internal Assessment	* Board Examination	Total		
4020310	Strength of Materials	25	100	100	40	3
4020320	Manufacturing Technology - I	25	100	100	40	3
4020330	Measurements and Metrology	25	100	100	40	3
4020340	Thermal Engineering – I	25	100	100	40	3
4020350	Machine Drawing and CAD Practical	25	100	100	50	3
4020360	Manufacturing Technology – I Practical	25	100	100	50	3
4020370	Measurements and Metrology Practical	25	100	100	50	3

* Examinations will be conducted for 100 Marks and will be converted 75 Marks.

Blank Page

IV Semester

Subject Code	SUBJECT	Marks			Minimum marks for pass	Duration of ExamHours
		Internal Assessment	* Board Examination	Total		
4020410	Fluid Mechanics and Fluid Power	25	100	100	40	3
4020420	Manufacturing Technology II	25	100	100	40	3
4020430	Electrical Drives and Controls	25	100	100	40	3
4020440	Production and Quality Management	25	100	100	40	3
4020450	Strength of Materials and Fluid Mechanics Practical	25	100	100	50	3
4020460	Manufacturing Technology II Practical	25	100	100	50	3
4020470	Electrical Drives and Control Practical	25	100	100	50	3

* Examinations will be conducted for 100 Marks and will be converted 75 Marks.

Blank Page

V Semester

Subject Code	SUBJECT	Marks			Minimum marks for pass	Duration of ExamHours
		Internal Assessment	* Board Examination	Total		
4020510	Design of Machine Elements	25	100	100	40	3
4020520	Thermal Engineering – II	25	100	100	40	3
ELECTIVE – I THEORY						
4020531	Computer Integrated Manufacturing	25	100	100	40	3
4020532	Green Energy and Energy Conservation	25	100	100		
4020533	Mechatronics	25	100	100		
4020540	Process Automation Practical	25	100	100	50	3
4020550	Thermal Engineering Practical	25	100	100	50	3
ELECTIVE – I PRACTICAL						
4020561	Computer Integrated Manufacturing Practical	25	100	100	50	3
4020562	Green Energy and Energy Conservation Practical	25	100	100		
4020563	Mechatronics Practical	25	100	100		
4020570	Entrepreneurship & Startup #	25	100	100	50	3

* Examinations will be conducted for 100 Marks and will be converted 75 Marks.

Blank Page

VI Semester

Subject Code	SUBJECT	Marks			Minimum marks for pass	Duration of ExamHours
		Internal Assessment	* Board Examination	Total		
4020610	Industrial Engineering and Management	25	100	100	40	3
4020620	E Vehicle Technology & Policy #	25	100	100	40	3
ELECTIVE – II THEORY						
4020631	Industrial Robotics and 3D Printing	25	100	100	40	3
4020632	Refrigeration and Air Conditioning	25	100	100		
4020633	Automobile Technology	25	100	100		
4020640	Solid Modelling Practical	25	100	100	50	3
ELECTIVE – II PRACTICAL						
4020651	Industrial Robotics and 3D Printing Practical	25	100	100	50	3
4020652	Refrigeration and Air Conditioning Practical	25	100	100		
4020653	Automobile Technology Practical	25	100	100		
4020660	Project Work and Internship	25	100	100	50	3

* Examinations will be conducted for 100 Marks and will be converted 75 Marks.

Blank Page

STATE BOARD OF TECHNICAL EDUCATION & TRAINING, TAMILNADU
DIPLOMA IN ENGINEERING / TECHNOLOGY SYLLABUS

N – SCHEME

ANNEXURE – I

CURRICULUM OUTLINE

3020: DIPLOMA IN MECHANICAL ENGINEERING (PART TIME)

THIRD SEMESTER

Subject Code	Subject	HOURS PER WEEK			
		Theory	Tutorial/ Drawing	Practical	Total
4020310	Strength of Materials	4	-	-	4
4020330	Measurements and Metrology	4	-	-	4
40015	Engineering Graphics - I	-	4	-	4
40001	Communication Skill Practical	-	-	3	3
4020370	Measurements and Metrology Practical	-	-	3	3
TOTAL		8	4	6	18

FOURTH SEMESTER

Subject Code	Subject	HOURS PER WEEK			
		Theory	Tutorial / Drawing	Practical	Total
4020320	Manufacturing Technology - I	4	-	-	4
4020340	Thermal Engineering - I	4	-	-	4
40025	Engineering Graphics - II	-	4	-	4
4020360	Manufacturing Technology – I Practical	-	-	3	3
40002	Computer Application Practical	-	-	3	3
TOTAL		8	4	6	18

Blank Page

FIFTH SEMESTER

Subject Code	Subject	HOURS PER WEEK			
		Theory	Tutorial/ Drawing	Practical	Total
4020410	Fluid Mechanics and Fluid Power	4	-	-	4
4020510	Design of Machine Elements	4	-	-	4
4020620	E Vehicle Technology & Policy	3	-	-	3
4020350	Machine Drawing and CAD Practical	-	2	2	4
4020450	Strength of Materials and Fluid Mechanics Practical	-	-	3	3
TOTAL		11	2	5	18

SIXTH SEMESTER

Subject Code	Subject	HOURS PERWEEK			
		Theory	Tutorial / Drawing	Practical	Total
4020420	Manufacturing Technology II	4	-	-	4
4020430	Electrical Drives and Controls	4	-	-	4
4020610	Industrial Engineering and Management	4	-	-	4
4020460	Manufacturing Technology II Practical	-	-	3	3
4020470	Electrical Drives and Control Practical	-	-	3	3
TOTAL		12	-	6	18

Blank Page

SEVENTH SEMESTER

Subject Code	Subject	HOURS PER WEEK			
		Theory	Tutorial/ Drawing	Practical	Total
4020520	Thermal Engineering - II	4	-	-	4
Elective-I Theory					
4020531	Computer Integrated Manufacturing	3	-	-	3
4020532	Green Energy and Energy Conservation				
4020533	Mechatronics				
4020540	Process Automation Practical	-	-	3	3
4020550	Thermal Engineering Practical	-	-	3	3
Elective-I Practical					
4020561	Computer Integrated Manufacturing Practical	-	-	3	3
4020562	Green Energy and Energy Conservation Practical				
4020563	Mechatronics Practical				
4020570	Entrepreneurship & Startups	-	-	2	2
TOTAL		7	-	11	18

Blank Page

EIGHTH SEMESTER

Subject Code	Subject	HOURS PER WEEK			
		Theory	Tutorial / Drawing	Practical	Total
4020440	Production and Quality Management	4	-	-	4
Elective-II Theory					
4020631	Industrial Robotics and 3D Printing	4	-	-	-
4020632	Refrigeration and Air Conditioning				
4020633	Automobile Technology				
4020640	Solid Modelling Practical	-	-	4	4
Elective-II Practical					
4020651	Industrial Robotics and 3D Printing Practical	-	-	3	3
4020652	Refrigeration and Air Conditioning Practical				
4020653	Automobile Technology Practical				
4020660	Project Work and Internship	-	-	3	3
TOTAL		8	-	10	18

Blank Page

STATE BOARD OF TECHNICAL EDUCATION & TRAINING, TAMILNADU
DIPLOMA IN ENGINEERING / TECHNOLOGY SYLLABUS

N – SCHEME

ANNEXURE – I

CURRICULUM OUTLINE

2020 DIPLOMA IN MECHANICAL ENGINEERING (SANDWICH)

III Semester

Subject Code	SUBJECT	HOURS PER WEEK			
		Theory hours	Drawing hours	Practical hours	Total hours
4020310	Strength of Materials	5	-	-	5
4020320	Manufacturing Technology - I	5	-	-	5
4020330	Measurements and Metrology	5	-	-	5
4020340	Thermal Engineering – I	5	-	-	5
4020350	Machine Drawing and CAD Practical	-	2	2	4
4020360	Manufacturing Technology – I Practical	-	-	4	4
4020370	Measurements and Metrology Practical	-	-	4	4
		20	2	10	32
Extra / Co-Curricular activities					
Library		-	-	-	1
Physical Education		-	-	-	2
TOTAL					35

Blank Page

IV Semester

Subject Code	SUBJECT	HOURS PER WEEK			
		Theory hours	Drawing hours	Practical hours	Total hours
4020420	Manufacturing Technology II	4	-	-	4
4020460	Manufacturing Technology II Practical	-	-	3	3
4020480	Industrial Training I	-	-	-	-
		4	-	3	7
Extra / Co-Curricular activities					
Library		-	-	-	-
Physical Education		-	-	-	-
TOTAL					-

Blank Page

V Semester

Subject Code	SUBJECT	HOURS PER WEEK			
		Theory hours	Drawing hours	Practical hours	Total hours
4020410	Fluid Mechanics and Fluid Power	5	-	-	5
4020430	Electrical Drives and Controls	5	-	-	5
4020520	Thermal Engineering – II	5	-	-	5
Elective I Theory					
4020531	Computer Integrated Manufacturing	5	-	-	5
4020532	Green Energy and Energy Conservation	5	-	-	
4020533	Mechatronics	5	-	-	
4020450	Strength of Materials and Fluid Mechanics Practical	-	-	3	3
4020470	Electrical Drives and Control Practical	-	-	3	3
4020550	Thermal Engineering Practical	-	-	3	3
Elective I Practical					
4020561	Computer Integrated Manufacturing Practical	-	-	3	3
4020562	Green Energy and Energy Conservation Practical	-	-	3	
4020563	Mechatronics Practical	-	-	3	
		20	-	12	32
Extra / Co-Curricular activities					
Library		-	-	-	1
Physical Education		-	-	-	2
TOTAL					35

Blank Page

VI Semester

Subject Code	SUBJECT	HOURS PER WEEK			
		Theory hours	Drawing hours	Practical hours	Total hours
4020620	E Vehicle Technology & Policy #	4	-	-	4
4020440	Production and Quality Management	5			5
4020510	Design of Machine Elements	6	-	-	6
4020610	Industrial Engineering and Management	4	-	-	4
Elective II Theory					
4020631	Industrial Robotics and 3D Printing	4	-	-	4
4020632	Refrigeration and Air Conditioning	4	-	-	
4020633	Automobile Technology	4	-	-	
4020540	Process Automation Practical	-	-	3	3
4020640	Solid Modelling Practical	-	-	3	3
Elective II Practical					
4020651	Industrial Robotics and 3D Printing Practical	-	-	3	3
4020652	Refrigeration and Air Conditioning Practical	-	-	3	
4020653	Automobile Technology Practical	-	-	3	
		23	-	9	32
Extra / Co-Curricular activities					
Library		-	-	-	1
Physical Education		-	-	-	2
TOTAL					35

Blank Page

VII Semester

Subject Code	SUBJECT	HOURS PER WEEK			
		Theory hours	Drawing hours	Practical hours	Total hours
4020570	Entrepreneurship & Startups	-	-	3	3
4020710	Project Work	-	-	4	4
4020720	Industrial Training II	-	-	-	-
		-	-	-	-
Extra / Co-Curricular activities					
Library		-	-	-	-
Physical Education		-	-	-	-
TOTAL					-

Blank Page

1020 Diploma in Mechanical Engineering

List of Equivalent Subjects for M- Scheme to N- Scheme

THIRD SEMESTER

M-SCHEME		N-SCHEME	
Subject code	Name of the Subject	Subject code	Name of Subject
32031	Strength of Materials	4020310	Strength of Materials
32032	Manufacturing Processes	4020320	Manufacturing Technology – I
32033	Machine Drawing		No Equivalent
32034	Computer Applications and CAD Practical		No Equivalent
32035	Foundry and Welding Practical		No Equivalent
32036	Lathe and Drilling Practical		No Equivalent
32037	Metrology and Metallography Practical		No Equivalent

FOURTH SEMESTER

M-SCHEME		N-SCHEME	
Subject code	Name of the Subject	Subject code	Name of Subject
32041	Heat Power Engineering	4020340	Thermal Engineering – I
32042	Special Machines	4020420	Manufacturing Technology II
32043	Fluid Mechanics and Fluid Power	4020410	Fluid Mechanics and Fluid Power
32044	Electrical Drives & Control	4020430	Electrical Drives and Controls
32045	Strength of Materials and Fluid Mechanics Practical	4020450	Strength of Materials and Fluid Mechanics Practical
32046	Special Machines Practice	4020460	Manufacturing Technology II Practical
32047	Electrical Drives & Control Practical	4020470	Electrical Drives and Control Practical

FIFTH SEMESTER

M-SCHEME		N-SCHEME	
Subject code	Name of the Subject	Subject code	Name of Subject
32051	Design of Machine Elements	4020510	Design of Machine Elements
32052	Thermal and Automobile Engineering		No Equivalent
32053	Process Planning and Cost Estimation		No Equivalent
Elective- I Theory			
32071	Total Quality Management		No Equivalent
32072	Press Tools		No Equivalent
32073	Renewable Energy Sources and Energy Conservation	4020532	Green Energy and Energy Conservation
32055	Process Automation Practical	4020540	Process Automation Practical
32056	Thermal and Automobile Engineering Practical		No Equivalent
30002	Life and Employability Skills Practical		40001 Communication Skill Practical

Blank Page

SIXTH SEMESTER

M-SCHEME		N-SCHEME	
Subject code	Name ofthe Subject	Subject code	Name ofSubject
32061	Industrial Engineering and Management	4020610	Industrial Engineering and Management
32062	Computer Aided Design and Manufacturing	4020531	Computer Integrated Manufacturing
Elective-II Theory			
32081	Mechanical Instrumentation		No Equivalent
32082	Robotics		No Equivalent
32083	Refrigeration and Air-conditioning	4020632	Refrigeration and Air Conditioning
32064	Computer Aided Design and Manufacturing Practical	4020561	Computer Integrated Manufacturing Practical
32065	Machine Tool Testing and Maintenance Practical		No Equivalent
Elective- II Practical			
32084	Mechanical Instrumentation Practical		No Equivalent
32085	Robotics Practical		No Equivalent
32086	Refrigeration and Air-conditioning Practical	4020652	Refrigeration and Air Conditioning Practical
32067	Project Work		No Equivalent

Blank page

STATE BOARD OF TECHNICAL EDUCATION & TRAINING, TAMILNADU
DIPLOMA IN ENGINEERING / TECHNOLOGY SYLLABUS
N-SCHEME

(To be implemented for the students admitted from the year 2020 - 2021 onwards)

Course Name : 1020 Diploma in Mechanical Engineering
 Subject Code : 4020310
 Semester : III
 Subject Title : Strength of Materials

TEACHING AND SCHEME OF EXAMINATION

No of weeks per semester: 16 weeks

Subject	Instructions		Examination			
	Hours / Week	Hours / Semester	Marks			Duration
Internal Assessment			Board Examinations	Total		
4020310 Strength of Materials	5	80	25	100*	100	3 Hrs.

* Examinations will be conducted for 100 marks and it will be reduced to 75 marks for result.

Topics and Allocation of Hours

Unit No	Topics	Hours
I	Engineering Materials	15
II	Deformation of Metals	15
III	Geometrical Properties of Sections and Thin Shells	15
IV	Theory of Torsion and Springs	14
V	SF and BM Diagrams of Beams and Theory of Bending	14
Test and Model Exam		7
Total		80

RATIONALE:

Day by day, engineering and technology experience tremendous growth. Design plays a major role in developing engineering and technology. Strength of material is backbone for design. The strength of material deals generally with the behaviour of objects, when they are subject to actions of forces. Evaluations derived from these basic fields provide the tools for investigation of mechanical structure.

OBJECTIVES

- Acquire knowledge about materials properties.
- Calculate the deformation of materials, which are subjected to axial load and shear.
- Determine the moment of Inertia of various sections used in industries.
- Estimate the stresses induced in thin shells.
- Draw the shear force and bending moment diagram of the beam for different load.

4020310 STRENGTH OF MATERIALS DETAILED SYLLABUS

Contents: Theory

Unit	Name of the Topics	Hours
I	ENGINEERING MATERIALS Chapter: 1.1: Engineering materials: Classification - definition of Mechanical properties - ferrous metals - cast iron - uses - advantages - types of cast iron - properties and applications - effect of impurities on cast iron. steel - classification - alloying elements - purpose of alloying - effect of alloying elements on steel - uses of steels - properties of mild steel - defects in steel - applications - properties of hard steel - market forms of steels – nonferrous metals - properties and uses. Chapter: 1.2: Mechanical testing of materials: Compression test - bend test - hardness test - Brinell hardness test, Vickers hardness test, Rockwell hardness test - impact test - fatigue test - creep test. Tensile test of mild steel in UTM - stress strain diagram -	7 6

	<p>only – Definition - centroidal axis - Axis of symmetry. Moment of Inertia – parallel axis theorem and perpendicular axis theorem (statement only). Moment of Inertia of lamina of rectangle, circle, triangle, I and channel sections – Definition - Polar moment of Inertia - radius of gyration – Problems computing moment of inertia and radius of gyration for angle, T, Channel and I sections.</p> <p>Chapter: 3.2: Thin Shells</p> <p>Definition – Thin and thick cylindrical shell – Failure of thin cylindrical shell subjected to internal pressure – Derivation of Hoop and longitudinal stress causes in a thin cylindrical shell subjected to internal pressure – simple problems – change in dimensions of a thin cylindrical shell subjected to internal pressure – problems – Derivation of tensile stress induced in a thin spherical shell subjected to internal pressure – simple problems – change in diameter and volume of a thin spherical shell due to internal pressure – problems.</p>	7
IV	<p>THEORY OF TORSION AND SPRINGS</p> <p>Chapter: 4.1: Theory of Torsion</p> <p>Assumptions – torsion equation $\frac{T}{J} = \frac{f_s}{R} = \frac{C\theta}{l}$ - Strength of solid and hollow shafts – power transmitted – Definition – Polar modulus – Torsional rigidity – strength and stiffness of shafts – comparison of hollow and solid shafts in weight and strength considerations – Advantages of hollow shafts over solid shafts – Problems.</p> <p>Chapter: 4.2: Springs</p> <p>Types of springs – Laminated and coiled springs and applications — Difference between open and closely coiled helical springs – closely coiled helical spring subjected to an axial load – problems to determine shear stress, deflection, stiffness and resilience of closed coiled helical springs.</p>	7 7
V	<p>SF AND BM DIAGRAMS OF BEAMS AND THEORY OF BENDING</p> <p>Chapter: 5.1: SF and BM diagrams</p> <p>Classification of beams – Definition – shear force and Bending moment – sign conventions for shear force and bending moment – types of</p>	7

	<p>loadings – Relationship between load, force and bending moment at a section – shear force diagram and bending moment diagram of cantilever and simply supported beam subjected to point load and uniformly distributed load (UDL) – Determination of Maximum bending moment in cantilever beam and simply supported beam when they are subjected to point load and uniformly distributed load.</p> <p>Chapter: 5.2: Theory of bending</p> <p>Theory of simple bending – Assumptions – Neutral axis – bending stress distribution – moment of resistance – bending equation – $M/I=f/y=E/R$ – Definition – section modulus - rectangular and circular sections – strength of beam – simple problems involving flexural formula for cantilever and simply supported beam.</p>	7
--	--	---

Reference Books:

1. Strength of Materials, R. S. Khurmi, S.Chand & Co., Ram Nagar, New Delhi.
2. Strength of Materials, S. Ramamrutham, 15th Edition 2004, DhanpatRai Pub. Co., New Delhi.
3. Strength of Materials, R.K. Bansal, Laxmi Publications Pvt. Ltd., New Delhi, 3rd Edition, 2010.
4. Strength of materials, S.S.Rattan, Tata Mcgraw hill, New Delhi,2008, ISBN 9780070668959,
5. Strength of Materials, B K Sarkar, I Edition, 2003Tata Mcgraw hill, New Delhi.
6. Engineering mechanics, R.K. Bansal, Laxmi Publications Pvt. Ltd., New Delhi, 2nd Edition, 2007.

Blank Page

STATE BOARD OF TECHNICAL EDUCATION & TRAINING, TAMILNADU
DIPLOMA IN ENGINEERING / TECHNOLOGY SYLLABUS
N - SCHEME

(To be implemented for the students admitted from the year 2020 - 2021 onwards)

Course Name : 1020 Diploma in Mechanical Engineering
 Subject Code : 4020320
 Semester : III
 Subject Title : Manufacturing Technology - I

TEACHING AND SCHEME OF EXAMINATION

No of weeks per semester: 16 weeks

Subject	Instructions		Examination			
	Hours / Week	Hours / Semester	Marks			Duration
Internal Assessment			Board Examinations	Total		
4020320 Manufacturing Technology - I	5	80	25	100*	100	3 Hrs.

* Examinations will be conducted for 100 marks and it will be reduced to 75 marks for result.

Topics and Allocation of Hours

Unit No	Topics	Hours
I	Casting Processes	15
II	Joining Processes	15
III	Bulk Deformation Processes and Heat Treatment	15
IV	Manufacturing of Plastic Components and Powder Metalurgy	15
V	Centre Lathe and Special Purpose Lathe	13
Test and Model Exam		7
Total		80

RATIONALE:

Manufacturing, the major and the most important aspect in industries needs utmost care and attention. Knowledge about various processes and allied areas will be of great use to the personnel involved in production. This will provide the students an opportunity to skill themselves for the industrial scenario.

OBJECTIVES:

- Acquire Knowledge about types of pattern, casting, and moulding.
- Describe the various casting processes.
- Knowledge about various welding process and its working principle.
- Appreciate the safety practices used in welding.
- Acquire knowledge about various forming technologies.
- Knowledge about the lathe and its working parts.
- Describe the functioning of semi-automatic lathes.

**4020320 MANUFACTURING TECHNOLOGY - I
DETAILED SYLLABUS**

Contents: Theory

Unit	Name of the Topics	Hours
I	<p>CASTING PROCESSES</p> <p>Chapter: 1.1: Patterns</p> <p>Definition – pattern materials – factors for selecting pattern materials – Types of Pattern - solid piece, split patterns, loose piece, match plate, sweep, skeleton, segmental, shell – pattern allowances – core prints.</p> <p>Chapter: 1.2: Moulding</p> <p>Definition – moulding boxes, moulding sand – ingredients – silica – clay – moisture and miscellaneous materials – properties of moulding sand – sand additives – moulding sand preparation - moulding tools – mixing – tempering and conditioning – types of moulding – green sand – dry sand – machine moulding –Top and bottom squeezer machines – Jolting machines – sand slinger- core – CO₂ core making – types of core – core boxes.</p>	<p>3</p> <p>6</p>

	<p>Chapter: 1.3: Casting</p> <p>Definition – sand casting using green sand and dry sand – gravity die casting – pressure die casting – hot and cold chamber processes – centrifugal casting – continuous casting – chilled casting – malleable casting – melting of cast iron – cupola furnace – melting of nonferrous metals – crucible furnace melting of steel - arc furnaces – induction furnaces – instrument for measuring temperature – optical pyrometer – thermo electric pyrometer – cleaning of casting – tumbling, trimming, sand and shot blasting – defects in casting – causes and remedies – safety practices in foundry.</p>	6
II	<p>JOINING PROCESSES</p> <p>Chapter: 2.1: Arc Welding</p> <p>Definition – arc welding equipment – arc welding methods – carbon arc, metal arc, Metal Inert gas (MIG), Tungsten inert gas (TIG), Atomic hydrogen, Plasma arc, Submerged arc and Electro slag welding.</p> <p>Chapter: 2.2: Gas welding</p> <p>Definition Gas Welding Equipment– Oxy and acetylene welding - Three types of flame– resistance welding – classification of resistance welding – butt – spot – seam – projection welding – welding related processes – oxy and acetylene cutting – arc cutting – hard facing bronze welding – soldering and brazing special welding processes – cast iron welding – thermit welding – solid slate welding, ultrasonic, diffusion and explosive welding – explosive cladding – modern welding, electron beam and laser beam welding – types of welded joints – merits and demerits of welded joints – inspection and testing of welded joints – destructive and nondestructive types of tests – magnetic particle test – radiographic and ultrasonic test defects in welding – causes and remedies – safety practices in welding .</p>	5 10
III	<p>BULK DEFORMATION PROCESSES AND HEAT TREATMENT</p> <p>Chapter: 3.1: Forming</p> <p>Hot working, cold working – advantages of hot working and cold working– hot working operations – rolling, forging, smith forging, drop</p>	7

	<p>forging, upset forging, press forging – roll forging Press working : Types of presses – Mechanical and Hydraulic presses – press tool and accessories – press working operations – bending operations – angle bending – chemical bending – curling – drawing – shearing operations – blanking, piercing, trimming – notching – lancing.</p> <p>Chapter: 3.2: Heat treatment</p> <p>Heat treatment processes – purpose – procedures – applications of various heat treatment processes – Iron – carbon equilibrium diagram – full annealing – process annealing stress relief annealing - spheroidising annealing – isothermal annealing – normalizing – hardening – tempering – quenching medium – different types and their relative merits – case hardening – pack carburizing – cyaniding – nitriding – induction hardening and flame hardening.</p>	8
IV	<p>MANUFACTURING OF PLASTIC COMPONENTS AND POWDER METALLURGY</p> <p>Chapter: 4.1: Plastic Components</p> <p>Types of plastics-Engineering plastics – thermosets – composite - structural foam, elastomers - polymer alloys and liquid crystal polymers.</p> <p>Chapter: 4.2: Processing of Plastics</p> <p>Extrusion-general features of single screw extrusion - twin screw extruders and types-Injection moulding types : Plunger type.- Reciprocating screw injection - details of injection mould - structural foam injection mould - sandwich moulding - gas injection moulding – injection moulding of thermosetting materials calendaring and rotational moulding. Design consideration for plastic components.</p> <p>Chapter: 4.3: Powder Metallurgy</p> <p>Methods of manufacturing metal powders – atomization, reduction and electrolysis deposition – compacting – sintering – sizing – infiltration – mechanical properties of parts made by powder metallurgy – design rules for the powder metallurgy process.</p>	3 6 6
V	<p>CENTRE LATHE AND SPECIAL PURPOSE LATHES</p> <p>Chapter: 5.1: Centre Lathe</p> <p>Centre lathe: specifications – simple sketch with principal parts. Head</p>	5

	<p>stock: back geared type – all geared type - description only. Working principle of tumbler gear mechanism, quick change gear box, apron mechanism, carriage cross slide. Feed mechanism: automatic feed, longitudinal feed and cross feed. Construction and working of tail stock. work holding device: face plate – three jaw chuck – four jaw chuck – catch plate and carrier – center. Operations: straight turning – step turning - taper turning – knurling-Thread cutting - Facing – Boring – chamfering. Cutting speed – feed - depth of cut.</p> <p>Chapter: 5.2: Semi-Automatic Lathes</p> <p>Types of semi-automatic lathes – capstan and turret lathes – difference between turret and capstan.</p> <p>Chapter: 5.3: Automatic Lathes</p> <p>Automatic lathe – Construction and working principle of single spindle automatic lathe – automatic screw cutting machines – multi spindle automatic lathes.</p>	<p>4</p> <p>4</p>
--	--	-------------------

Reference Books:

1. Elements of workshop Technology Volume I & II – Hajra Chowdry & Bhattacharaya - IIth Edition - Media Promoters & Publishers Pvt. Ltd., Seewai Building 'B', 20-G, Noshir Bharucha Marg, Mumbai 400 007 – 2007.
2. Introduction of basic manufacturing processes and workshop technology – Rajendersingh – New age International (P) Ltd. Publishers, 4835/24, Ansari Road, Daryaganj, New Delhi – 110002.
3. Manufacturing process – Begeman - 5th Edition -McGraw Hill, New Delhi 1981.
4. Workshop Technology- WAJ Chapman - Volume I, II, & III – Vima Books Pvt. Ltd., 4262/3, Ansari Road, Daryaganj, New Delhi 110 002.
5. Workshop Technology – Raghuwanshi - Khanna Publishers. Jain & Gupta,
6. Production Technology, Edn. XII, Khanna Publishers, 2-B, North Market, NAI Sarak, New Delhi 110 006 - 2006
7. Production Technology - P. C. SHARMA - Edn. X - S.Chand & Co. Ltd., Ram Nagar, New Delhi 110 055 - 2006
8. Production Technology – HMT - Edn. 18 - published by Tata McGraw Hill publishing Co. Ltd., 7 West Patel nagar, New Delhi 110 008. – 2001.

Blank Page

STATE BOARD OF TECHNICAL EDUCATION & TRAINING, TAMILNADU
DIPLOMA IN ENGINEERING / TECHNOLOGY SYLLABUS
N - SCHEME

(To be implemented for the students admitted from the year 2020 - 2021 onwards)

Course Name : 1020 Diploma in Mechanical Engineering
 Subject Code : 4020330
 Semester : III
 Subject Title : Measurements and Metrology

TEACHING AND SCHEME OF EXAMINATION

No of weeks per semester: 16 weeks

Subject	Instructions		Examination			
	Hours / Week	Hours / Semester	Marks			Duration
Internal Assessment			Board Examinations	Total		
4020330 Measurements and Metrology	5	80	25	100*	100	3 Hrs.

* Examinations will be conducted for 100 marks and it will be reduced to 75 marks for result.

Topics and Allocation of Hours

Unit No	Topics	Hours
I	Basic Concepts of Measurements	15
II	Linear and Angular Measurements	15
III	Form Measurement	15
IV	Advances in Metrology	14
V	Measurement of Mechanical Parameters	14
Test and Model Exam		7
Total		80

RATIONALE:

Measurements and metrology are the basic and prominent tools in all the industries in the present scenario. The students should be trained not only in manufacturing also they should have knowledge about the various measuring instruments which is used in industries. This will provide the students an opportunity to skill themselves for how to handle the various metrological equipment available to measure the dimensions of the components.

OBJECTIVES

- Study about the basic concepts of measurements.
- Acquire knowledge about precision and accuracy.
- Describe about the various linear and angular measurements.
- Acquire knowledge about the measurement of screw threads and gears.
- Study about the laser metrology and computer in metrology.
- Describe the measurement of mechanical parameters force, power and flow.

4020330 MEASUREMENTS AND METROLOGY DETAILED SYLLABUS

Contents: Theory

Unit	Name of the Topics	Hours
I	BASIC CONCEPTS OF MEASUREMENTS Chapter: 1.1: Introduction Basic units - system concepts used in measuring technology - measuring instruments - length, angles and surface - scope of Metrology - standardization - international standardization, the bureau of Indian standards - legal Metrology - definition - applications - important elements of measurements - methods of measurements - needs for inspection - need for measurement - important terminology.	7
	Chapter: 1.2: Precision and accuracy Precision - definition - accuracy - definition - difference between precision and accuracy - factors affecting the accuracy of the measuring system - general rules for accurate measurements -	8

	<p>gear measurement - run out, tooth measurement, profile measurement, lead checking , backlash checking, tooth thickness measurement - vernier gear tooth caliper - David brown tangent comparator - constant chord method - measurement of concentricity, alignment checking - Parkinson gear tester - Rolling gear testing machine - radius measurement - radius of circle - surface finish measurement - classification of geometrical irregularities - elements of surface texture - methods of measuring surface finish - measuring surface roughness - tracer type profilogram - double microscope.</p>	
IV	<p>ADVANCES IN METROLOGY</p> <p>Chapter: 4.1: Laser Metrology</p> <p>Basic concepts of lasers - types of lasers - uses, advantages and applications - laser telemetric system - laser and LED based distance measuring instruments - scanning laser gauge - photodiode array imaging - diffraction pattern technique - laser triangulation sensors - two frequency laser interferometer - gauging wire diameter from the diffraction pattern formed in laser - interferometry - use of laser in interferometry - interferometer - standard interferometer, single beam interferometer, AC interferometer, Michelson interferometer, dual frequency laser interferometer - Twyman green interferometer - applications.</p> <p>Chapter: 4.2: Computer in Metrology</p> <p>Coordinating measuring machine - introduction - types of measuring machines - types of CMM - futures of CMM - causes of errors in CMM - 3 co-ordinate measuring machine - performance of CMM - applications - advantages disadvantages - computer controlled coordinating measuring machine - mechanical system of computer controlled CMMs - trigger type probe system, measuring type prop system, features of CNC and CMM - features of CMM software - factors affecting CMM - digital devices - Computer based inspection - Computer aided inspection using robots.</p>	<p>7</p> <p>7</p>

V	<p>MEASUREMENT OF MECHANICAL PARAMETERS</p> <p>Chapter: 5.1: Force</p> <p>Measurement of force - Direct methods - equal arm balance, unequal arm balance, multiple lever system, pendulum scale - indirect methods - electromagnetic balance - load cells - hydraulic load cell, pneumatic load cell, strain gauge load cell, shear type load cell, electronic weighing system. Torque measurement - torque measurement using strain gauge - laser optical torque measurement - stroboscope for torque measurement.</p> <p>Chapter: 5.2: Measurement of power</p> <p>Mechanical dynamometer - DC dynamometer - inductor dynamometer - hydraulic dynamometer - diaphragm pressure sensor - deform cage with LVDT - diaphragm gauge with strain gauges - piezoelectric sensors.</p> <p>Chapter: 5.3: Measurement of flow</p> <p>Types of flow metres - rotameter, electromagnetic flow metre, hot wire anemometer, ultrasonic flow metre, laser Doppler anemometer (LDA) - reference beam mode, interference French mode.</p>	<p>6</p> <p>4</p> <p>4</p>
---	---	----------------------------

Reference Books:

1. Mechanical Measurements and Instrumentation, Rajput R K, S.K.Kataria and Sons.
2. Mechanical Measurement and Control, Jalgaonkar R.V, Everest Publishing House.
3. Mechanical and Industrial Measurements, Jain R K, Khanna Publications.
4. Instrumentation Devices and Systems, Narang C S, Tata McGraw Hill Publications.
5. Instrumentation, Measurement and Analysis, Nakra B.C, Chaudhary K.K, Tata McGraw Hill Publications.

Blank Page

STATE BOARD OF TECHNICAL EDUCATION & TRAINING, TAMILNADU
DIPLOMA IN ENGINEERING / TECHNOLOGY SYLLABUS
N - SCHEME

(To be implemented for the students admitted from the year 2020 - 2021 onwards)

Course Name : 1020 Diploma in Mechanical Engineering
 Subject Code : 4020340
 Semester : III
 Subject Title : Thermal Engineering - I

TEACHING AND SCHEME OF EXAMINATION

No of weeks per semester: 16 weeks

Subject	Instructions		Examination			
	Hours / Week	Hours / Semester	Marks			Duration
Internal Assessment			Board Examinations	Total		
4020340 Thermal Engineering - I	5	80	25	100*	100	3 Hrs.

* Examinations will be conducted for 100 marks and it will be reduced to 75 marks for result.

Topics and Allocation of Hours

Unit No	Topics	Hours
I	Basics of Thermodynamics and Thermodynamic processes of Perfect Gases	15
II	Thermodynamic Air Cycles and Heat Transfer	15
III	Internal Combustion Engines	15
IV	Fuels & Combustion of Fuels and Performance of IC Engines	15
V	Refrigeration and Air Conditioning	13
Test and Model Exam		7
Total		80

RATIONALE:

The growth of industries in the areas of Automobile and thermal power generation is the contemporary need of the present day. For these industries Knowledge on the concept of Thermodynamics, Thermodynamic Processes, Steady flow energy equation and study of fuels, IC Engines and performance of IC Engines are vital.

OBJECTIVES:

- Explain the basics of systems and laws of thermodynamic and Thermodynamic processes.
- Explain different type of fuels and their combustion phenomenon.
- Explain the types, functions and the performance tests of IC engines.
- Explain vapour compression refrigeration system.
- Explain vapour absorption refrigeration system.
- Compare the properties and applications of various refrigerants.
- Describe the equipment used for air conditioning.

4020340 THERMAL ENGINEERING - I**DETAILED SYLLABUS****Contents: Theory**

Unit	Name Of The Topic	Hours
I	<p>BASICS OF THERMODYNAMICS AND THERMODYNAMIC PROCESSES OF PERFECT GASES</p> <p>Introduction – definitions and units of mass, weight, volume, density, work –power- energy – types- specific weight, specific gravity and specific volume – pressure – units of pressure –temperature - absolute temperature – S.T.P and N.T.P conditions – heat -specific heat capacity at constant volume and at constant pressure – law of conservation of energy – thermodynamic system– types – thermodynamic equilibrium - properties of systems – intensive and extensive properties –State of System- process – cycle – point and path functions - zeroth, first and second laws of thermodynamics. Description of basic concepts only.</p>	5

	<p>Perfect gases – laws of perfect gases – Boyle’s, Charles’, Joule’s, Regnault’s and Avogadro’s laws –General Gas Equation-characteristic gas equation – relation between specific heats and gas constant – universal gas constant –Thermodynamic Processes-Change in Internal Energy- enthalpy –change in enthalpy – entropy – change in entropy – general equations for change in entropy. Description only.</p> <p>Constant volume, constant pressure, isothermal, isentropic (reversible adiabatic) – Description and problems. Polytropic (derivation only), hyperbolic (derivation only) – P-V and T-S diagrams, work done, change in internal energy, heat transfer, change in enthalpy, change in entropy for various processes - Free expansion and throttling processes.</p>	5
		5
II	<p>THERMODYNAMIC AIR CYCLES AND HEAT TRANSFER</p> <p>Air cycles – air standard efficiency – reversible and irreversible processes –assumptions in deriving air standard efficiency – Carnot cycle – Otto cycle –Joule cycle – Diesel cycle – comparison of Otto cycle and Diesel cycle -Comparison of ideal and actual p-V diagrams of Otto and Diesel cycles –problems .</p> <p>Modes of heat transfer – heat transfer by conduction – Fourier’s Law– heat transfer by convection –heat exchanger – Parallel flow and Counter flow– heat transfer by radiation – Description only.</p> <p>Steady flow system – control volume – steady flow energy equation – assumptions –Engineering applications of steady flow energy equation – non flow energy equation. Description only.</p>	5
		5
III	<p>INTERNAL COMBUSTION ENGINES</p> <p>Internal combustion engines. Classifications of I.C Engines – components of I.C Engines and functions material and method of manufacturing - four stroke cycle petrol and diesel engines – two stroke cycle petrol and diesel engines - comparison of four stroke and two stroke engines – Comparison of petrol and diesel engines - valve timing diagram for four stroke petrol and diesel engines – port timing diagram for two stroke petrol and diesel engines. Layout of fuel</p>	10

	<p>depression – humidity – specific and relative humidity – psychrometric chart – psychrometric processes – sensible heating and cooling - Bypass Factor - humidification – dehumidification –Mixing of Air Stream. Air conditioning – classification and applications of air conditioning system – room air conditioning – central air conditioning – comparison – comfort and industrial air conditioning – factors to be considered in air conditioning – loads encountered in air conditioning systems. Description only.</p>	
--	---	--

Reference Books:

1. Thermal Engg, R.K.Rajput, 8th Edition, Laxmi publications Pvt Ltd , New Delhi.
2. Applied Thermodynamics, P.K. Nag, 2nd Edition, TATA Mcgraw – Hill Publishing Company, New Delhi .
3. Thermal Engineering, R.S. Khurmi and J.K. Gupta, 18th Edition, S. Chand & Co, New Delhi.
4. Thermal Engineering, P.L Ballaney , 24th Edition Khanna Publishers, New Delhi.
5. Thermal Engineering, B.K. Sarkar , 3rd Edition , Dhanpat Rai & Sons New Delhi .
6. Applied Thermodynamics, Domkundwar and C.P Kothandaraman, 2nd Edition Khanna publishers, New Delhi.

Blank Page

STATE BOARD OF TECHNICAL EDUCATION & TRAINING, TAMILNADU
DIPLOMA IN ENGINEERING / TECHNOLOGY SYLLABUS
N - SCHEME

(To be implemented for the students admitted from the year 2020 - 2021 onwards)

Course Name : 1020 Diploma in Mechanical Engineering
 Subject Code : 4020350
 Semester : III
 Subject Title : Machine Drawing and CAD Practical

TEACHING AND SCHEME OF EXAMINATION

No of weeks per semester: 16 weeks

Subject	Instructions		Examination			
	Hours / Week	Hours / Semester	Marks			Duration
Internal Assessment			Board Examinations	Total		
4020350 Machine Drawing and CAD Practical	4	64	25	100*	100	3 Hrs.

* Examinations will be conducted for 100 marks and it will be reduced to 75 marks for result.

RATIONALE:

Mechanical Engineering Diploma Engineer is expected to possess a thorough understanding of drawing, which includes clear visualization and proficiency in reading and interpreting a wide variety of production drawing. Manufacturing of various parts start from the basic drawing of components. The assembly of components is also carried out from the drawing. So drawing is an important subject to be studied by the students to carry and complete the production and assembly process successfully.

OBJECTIVES:

- To learn the parts and assembly of the machine components.
- To appreciate the need for sectional view and types of sections.
- To draw sectional views.
- To practice manual drawing

- To use Computer Aided Drafting.
- To prepare geometrical model of various machine elements.
- To draw the different views of machine elements.
- To interpret the drawing in engineering field and illustrate three dimensional objects.

4020350 MACHINE DRAWING AND CAD PRACTICAL

DETAILED SYLLABUS

Contents: Practical

PART-A: MANUAL DRAWING PRACTICE

Sectioning - sectional views – representation of sectional plane – hatching – inclination – spacing – hatching large areas – hatching adjacent parts - full section – half section – types of half sections – conventional representation of materials in section – Dimensioning.

Detailed drawings of the machine parts are given to students to assemble and draw any two views of the machine elements in the Drawing Sheet with dimensions. Front View /Full Section / Half Section Front View and Top View / Left Side View / Right Side View.

PART-B: COMPUTER AIDED DRAFTING (CAD)

CAD applications – Hardware requirement – Software requirement – CAD screen interface – menus – Toolbars – types of co-ordinate system – Creating 2D objects – Using draw commands – Creating text – Drawing with precision – Osnap options – drafting settings – drawing aids – Fill, Snap, Grid, Ortho lines – Function keys – Editing and modify commands – Object selection methods – Erasing object – Oops – Cancelling and undoing a command – Copy – Move – Array – Offset – Scale – Rotate – Mirror – Break – Trim – Extend – Explode. Divide – Measure – stretch – Lengthen – Changing properties – Color – line types – LTscale – Matching properties – Editing with grips – Pedit – Ddedit – Mledit - Basic dimensioning – Editing dimensions – Dimension styles – Dimension system variables. Machine drawing with CAD. Creation of blocks – Wblock – inserting a block – Block attributes – Hatching – Pattern types – Boundary hatch – working with layers – Controlling the drawing display – Blipmode – View group commands – Zoom, redraw, regen,

regenauto, pan, viewers – Realtime zoom. Inquiry groups – calculating area – Distance – Time – Status of drawing – Using calculator. Plot

Detailed drawings of the machine parts are given to students to assemble and create two views of the machine elements in the CAD package with dimensions. Front View / Sectional Front View (Full Section / Half Section) and Top View / Left Side View / Right Side View.

EXERCISE:

Draw the Front View / Sectional Front View (Full Section / Half Section) and Top View / Left Side View / Right Side View for the following given part drawing of the components after assemble in the drawing sheet and CAD package.

1. Sleeve & Cotter joint
2. Screw jack
3. Plummer Block
4. Simple Eccentric
5. Machine Vice
6. Protected type flanged coupling

Reference Books:

1. A Textbook of Machine Drawing, Pritam Singh Gill, S.K.Kataria & Sons.
2. Machine Drawing, N.D.Bhatt, V.M.Panchal, Charoter Publishing House.
3. Introducing Autocad 2010 and Autocad LT 2010, George Omura, Wiley India Pvt. Ltd.
4. A Textbook of Engineering Drawing, R.B.Gupta, Satya Prakasan, Technical India Publications.
5. Engineering Drawing, D.N. Ghose, Dhanpat Rai & Sons, Delhi

Internal Mark Allocation

Note:

All the students should maintain the observation cum record note book / manual as per the regulation. The printout of the actual CAD output created by the student during practice should be pasted for every exercise in the observation cum record note work.

For every exercise, manual drawing sheet (Two views) should be submitted and evaluated for 50 Marks. (Front view – 30 Marks and Top view/Side view – 20 Marks).

The average of the six exercises should be converted to 10 Marks.

Drawing Sheet (Six Exercise Average)	-	10 Mark
Observation and Record work	-	10 Mark
Attendance	-	05 Marks
Total	-	25 Marks

BOARD EXAMINATION

Note: All the exercises should be completed by Manual and CAD. All the exercise should be given for examination, the students are permitted to select by lot or the question paper from DOTE should be followed. Observation cum Record note book should be submitted during examination along with the drawing file. Part A and Part B should be completed for the examination.

PART A: Manual Drawing in the Drawing sheet

Draw the assemble Front View / Sectional Front View (Full Section / Half Section) for the given part drawing of the components in the drawing sheet.

PART B: Computer Aided Drafting in the CAD package

Create the assemble Front View / Sectional Front View (Full Section / Half Section) and Top View / Left Side View / Right Side View for the given part drawing of the components in any one of the CAD package.

DETAILED ALLOCATION OF MARKS

Manual Drawing in Drawing sheet		: 30 marks
Assemble Front view	30	
Computer Aided Drafting		: 60 marks
Drafting	20	
Assembly	20	
Dimensioning	20	
Viva-voce		: 10 marks
Total		: 100 marks

LISTOF EQUIPMENT (For 30 students)

1. Personal computer – 30 Nos.
2. Printer – 1 No.
3. Required Software's: CAD Package – Sufficient to the strength.

Blank Page

STATE BOARD OF TECHNICAL EDUCATION & TRAINING, TAMILNADU
DIPLOMA IN ENGINEERING / TECHNOLOGY SYLLABUS
N - SCHEME

(To be implemented for the students admitted from the year 2020 - 2021 onwards)

Course Name : 1020 Diploma in Mechanical Engineering
 Subject Code : 4020360
 Semester : III
 Subject Title : Manufacturing Technology - I Practical

TEACHING AND SCHEME OF EXAMINATION

No of weeks per semester: 16 weeks

Subject	Instructions		Examination			
	Hours / Week	Hours / Semester	Marks			Duration
Internal Assessment			Board Examinations	Total		
4020360 Manufacturing Technology - I Practical	4	64	25	100*	100	3 Hrs.

* Examinations will be conducted for 100 marks and it will be reduced to 75 marks for result.

OBJECTIVES:

- Identify the parts of a center lathe
- Identify the work holding devices
- Set the tools for various operations
- Operate the lathe and Machine a component using lathe
- Identify the tools used in foundry.
- Identify the tools and equipments used in welding
- Prepare sand moulds for different patterns.
- Perform welding operation to make different types of joints.
- Identify the different welding defects.
- Appropriate the safety practices used in welding

4020360 MANUFACTURING TECHNOLOGY - I PRACTICAL
DETAILED SYLLABUS

Contents: Practical

Lathe: Study of Lathe parts and its functions – Operations - Plain Turning , Step Turning, Taper turning, Knurling, Thread cutting, Bushing, Eccentric Turning

Foundry: Study of foundry - green sand – properties – patterns – Types - Solid Pattern - Stepped pulley, Bearing top, Gear wheel. Split Pattern - T Pipe, Bent Pipes, Dumbles - Loose Piece pattern – Dovetail – Core – Cores sand - Cylindrical core making

Welding Exercises

Arc welding principles and components - Arc Welding - Lap Joint - Butt Joint, T Joint, Corner joint. Gas welding equipments – components - Gas welding - Lap Joint, Butt Joint, T Joint, Corner Joint. Gas cutting - Spot Welding

Exercises

PART A – Lathe Exercises

Note: All Dimensions are in mm. All linear dimensions in $\pm 0.5\text{mm}$ tolerance. All cylindrical dimensions in $\pm 0.2\text{mm}$ tolerance. Estimate the cost of the job for following exercises for M.S. round rod with suitable raw material for the final size. Final job of the raw material should be retained for verification. (student wise or batch wise).

1. Prepare the specimen and make the Step turning & Taper turning as shown in figure using the Lathe.

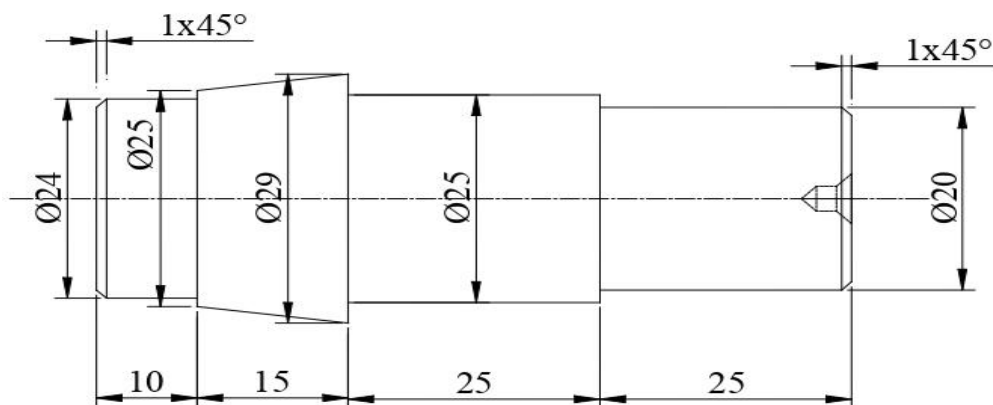

2. Prepare the specimen and make the Step turning & Knurling as shown in figure using the Lathe.

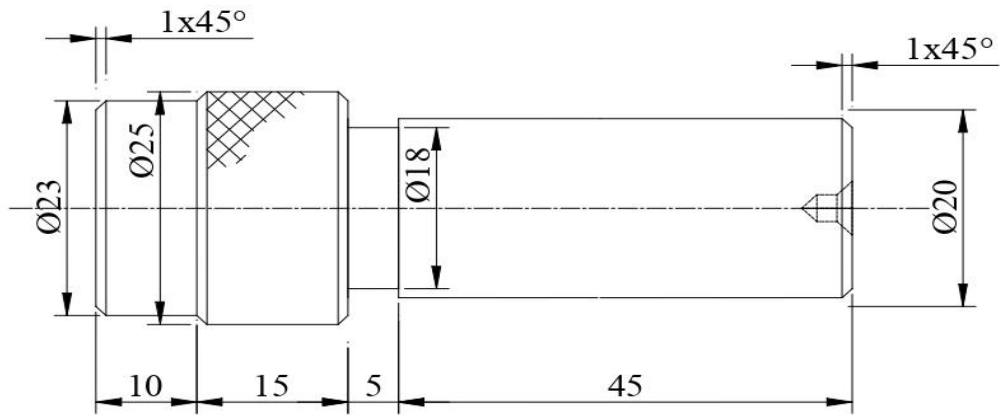

3. Prepare the specimen and make the Step turning &BSW Thread cutting as shown in figure using the Lathe.

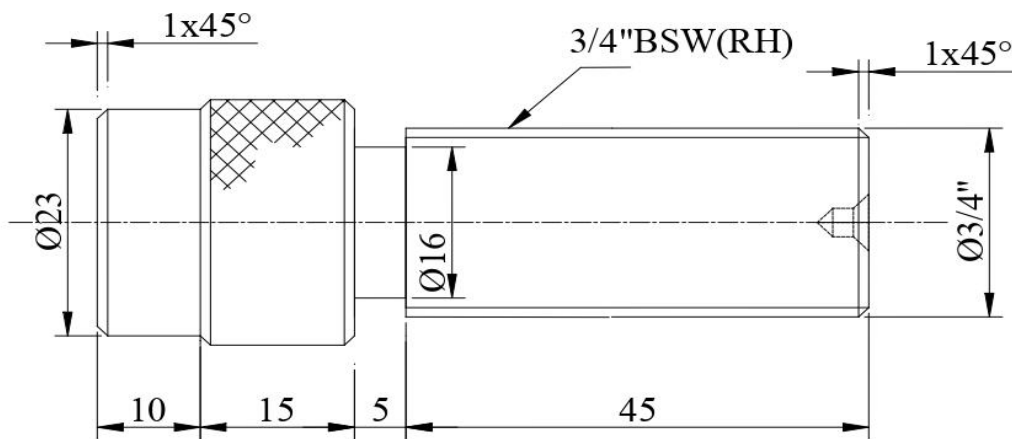

4. Prepare the specimen and make the Shaft and Bush as shown in figure using the Lathe.

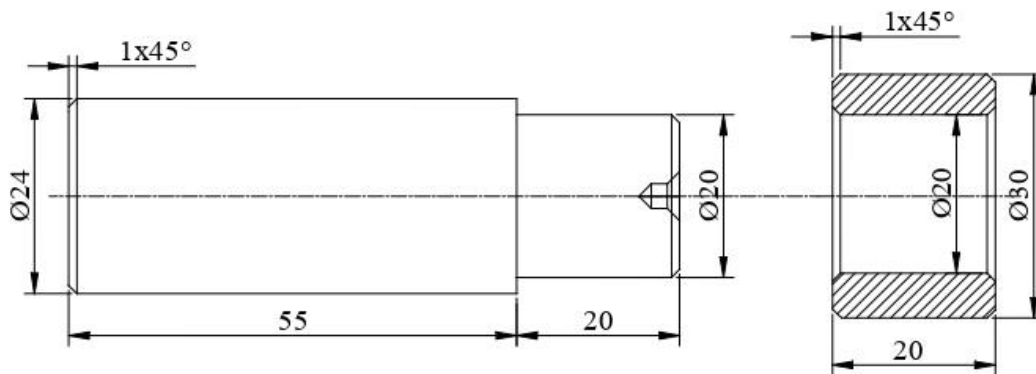

5. Prepare the specimen and make the Step turning & BSW and Metric Thread cutting as shown in figure using the Lathe.

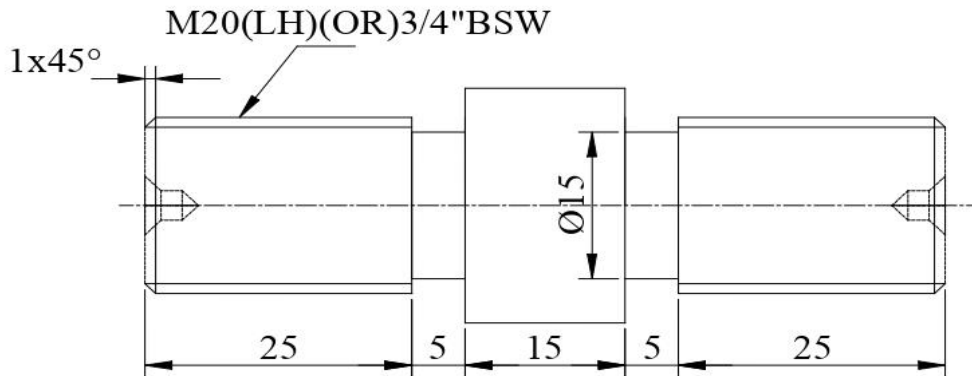

6. Prepare the specimen and make the Eccentric turning as shown in figure using the Lathe.

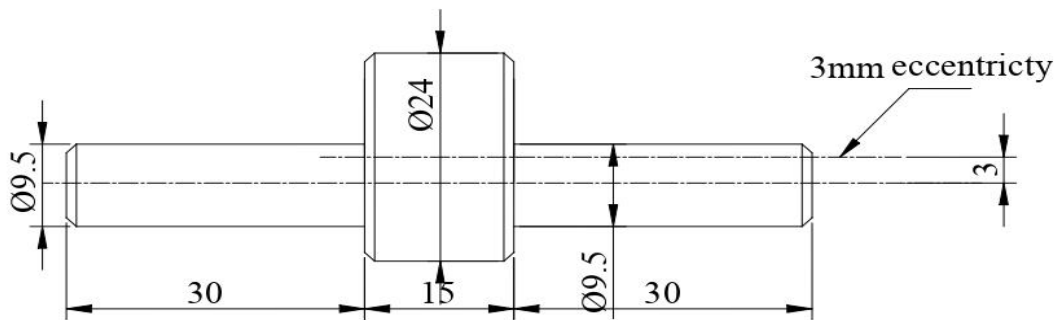

PART B – Exercises

1. Prepare the green sand moulding using any one Solid Pattern in the foundry.
2. Prepare the green sand moulding using any one Split Pattern in the foundry.
3. Prepare the green sand moulding using any one Loose Piece pattern in the foundry.
4. Prepare the specimen and make the Lab joint by the Arc Welding (Both side welded). (Raw material 25mm X 6mm MS flat)
5. Prepare the specimen and make the corner joint by the Gas Welding. (Raw material 25mm X 3mm MS sheet)
6. Prepare the specimen and make the Butt joint by the Spot welding. (Raw material 25mm X 3mm GI sheet)

BOARD EXAMINATION

Note:

- All the exercises in both sections have to be completed. Two exercises will be given for examination by selecting one exercise from PART A and one exercise from PART B.
- All the exercises should be given in the question paper and students are allowed to select by a lot or Question paper issued from the DOTE should be followed.
- All regular students appearing for first attempt should submit record notebook for the examination.
- The external examiner should verify the availability of the facility for the batch strength before commencement of practical examination.
- The external examiner should verify the working condition of machinery's / equipment before commencement of practical examination.

DETAILED ALLOCATION OF MARKS

Part - A	:	55 marks
Procedure / Preparation	10	
Machining / Dimensions	35	
Finishing	10	
Part - B	:	40 marks
Procedure / Preparation	10	
Machining / Dimensions	25	
Finishing	5	
Viva voce	:	05 marks
Total	:	100Marks

LIST OF EQUIPMENT (For 30 students)

1. Center Lathe 4 ½ ' Bed length	– 10 No's
2. 4 Jaw / 3 Jaw Chucks	– required Numbers
3. Chuck key (10 mm x 10 mm size)	– 10 No's
4. Box spanner	– 1 No's
5. Cutting Tool H.S.S ¼ " X ¼ " X 4 " long	– 10 No's
6. Pitch gauge	– 5 Nos
7. Vernier Caliper (0-25 and 25-50)	– 5 Nos each
8. Micrometer, Inside and Outside(0-25 and 25-50)	- 5 each
9. Vernier Height Gauge(300mm)	- 1 no
10. Snap gauge	– 1 set
11. Gear tooth Vernier	- 1 No
12. Parallel Block	- 2 Nos
13. Steel Rule (0-150)	– 10 Nos.
14. Outside and Inside Calipers	- 10 Nos. each
15. Thread gauge	– 5 Nos.
16. Bevel Protractor	– 1 No
17. Jenny Caliper	– 5 Nos.
18. Dial Gauge with Magnetic Stand	– 5 Nos.
19. Marking Gauge	– 10 Nos.
20. Safety Glass	– 10 Nos.
21. Arc welding booth	– 2 No's
with oil /air cooledwelding transformer withaccessories	
22. Gas welding unit (Oxygen and acetylene cylinder)	– 1 Set
23. Flux	– 500 g
24. Electrode 10 SWG	– 200 No's
25. Face shield	– 3 No's
26. Gas welding goggles	– 2 No's
27. Leather Glows 18"	– 4 Set
28. Flux chipping hammer	– 4 No's
29. Spot welding machine	- 1 No
30. Crucible furnace	- 1 No
31. Tilting furnace	- 1 No
32. Shovel	- 10 Nos

33. Rammer set	- 10 Nos
34. Slick	- 10 Nos
35. Strike-off bar	- 10 Nos
36. Riddle	- 10 Nos
37. Trowl	- 10 Nos
38. Lifter	- 10 Nos
39. Sprue pin	- 20 Nos
40. Brush	- 10 Nos
41. Vent rod	- 10 Nos
42. Draw spike	- 10 Nos
43. Gate cutter	- 10 Nos
44. Cope box	- 10 Nos
45. Drag box	- 10 Nos
46. Core box	- 10 Nos
47. Runner & riser	- 20 Nos
48. Moulding board	- 10 Nos
49. Patterns	- 5 Nos each

Blank Page

**STATE BOARD OF TECHNICAL EDUCATION & TRAINING, TAMILNADU
DIPLOMA IN ENGINEERING / TECHNOLOGY SYLLABUS**

N - SCHEME

(To be implemented for the students admitted from the year 2020 - 2021 onwards)

Course Name : 1020 Diploma in Mechanical Engineering

Subject Code : 4020370

Semester : III

Subject Title : Measurements and Metrology Practical

TEACHING AND SCHEME OF EXAMINATION

No of weeks per semester: 16 weeks

Subject	Instructions		Examination			
	Hours / Week	Hours / Semester	Marks			Duration
Internal Assessment			Board Examinations	Total		
4020370 Measurements and Metrology Practical	4	64	25	100*	100	3 Hrs.

* Examinations will be conducted for 100 marks and it will be reduced to 75 marks for result.

OBJECTIVES:

- Familiarize about measuring techniques of Metrology instruments.
- Select the range of measuring tools. Study of accuracy of instruments and calibration of instruments.
- Obtain accurate measurements.
- Determine the least count of measuring instruments.
- Acquire knowledge about linear measurement.
- Acquire knowledge about angular measurement.
- Acquire knowledge about geometric measurements.
- Study of Linear Measuring Instruments: Vernier Caliper, Micrometer, Inside Micrometer, Vernier Height gauge and Slip Gauge.
- Study of Angular Measuring Instruments—Universal Bevel Protractor, Sine Bar.

- Study of Geometric measurement - Gear tooth Vernier, Thread Vernier.

Exercises

PART A:

1. Measure the dimensions of ground MS flat / cylindrical bush using Vernier Caliper compare with Digital / Dial Vernier Caliper.
2. Measure the diameter of a wire using micrometer and compare the result with digital micrometer
3. Measure the thickness of ground MS plates using slip gauges
4. Measure the inside diameter of the bore of a bush cylindrical component using inside micrometer compare the result with digital micro meter.
5. Measure the height of gauge blocks or parallel bars using vernier height gauge.
6. Detect of cracks of the given two specimens using liquid penetrant test and magnetic particle test.
- 7.

PART B:

1. Measure the angle of a V-block / Taper Shank of Drill / Dovetail using universal bevel protractor.
2. Measure the angle of the machined surface using sine bar with slip gauges.
3. Measure the geometrical dimensions of V-Thread using thread micrometer.
4. Measure the geometrical dimensions of spur gear.
5. Find out the measurement of given component and compare with a standard component using mechanical comparator and slip gauge .
6. Prepare a specimen to examine and find the grain structure using the Metallurgical Microscope.

BOARD EXAMINATION

Note:

- All the exercises in both sections have to be completed. Two exercises will be given for examination by selecting one exercise from PART A and one exercise from PART B.
- All the exercises should be given in the question paper and students are allowed to select by a lot or Question paper issued from the DOTE should be followed.
- All regular students appearing for first attempt should submit record notebook for the examination.
- The external examiner should verify the availability of the facility for the batch strength before commencement of practical examination.
- The external examiner should verify the working condition of machinery's / equipment before commencement of practical examination.

DETAILED ALLOCATION OF MARKS

Part-A	:	45 marks
Procedure / Preparation	10	
Observation / Dimensions	25	
Finishing	10	
Part-B	:	45 marks
Procedure / Preparation	10	
Observation / Dimensions	25	
Finishing	10	
Viva-voce	:	10 marks
Total	:	100Marks

LIST OF EQUIPMENTS (For 30 students)

1. Vernier Caliper - 2 Nos.
2. Digital / Dial Vernier Caliper. - 2 Nos.
3. Outside micrometer - 2 Nos.
4. Inside Micrometer - 2 Nos
5. Digital Micrometer - 2 Nos.
6. Slip gauges - 2 Nos.
7. Universal bevel protractor. - 2 Nos.
8. Sine bar - 2 Nos.
9. Digital inside micrometer - 2 Nos.
10. Surface plate - 2 Nos.
11. Vernier height gauge - 1No.
12. Thread Vernier - 1 No.
13. Thread micrometer – 1 No.
14. Gear tooth Vernier - 2 Nos.
15. Mechanical comparator - 2 Nos.
16. Dial indicator (0-10) - 2 Nos.
17. Abrasive grinder – 1 No.
18. Polishing Machine – 1 No.
19. Mounting machine – 1 No.
20. Metallurgical microscope – 2 Nos
21. Magnetic yoke - 1 No.
22. Liquid penetrant test kit – 1 set.
23. Consumable - Sufficient quantity

STATE BOARD OF TECHNICAL EDUCATION & TRAINING, TAMILNADU
DIPLOMA IN ENGINEERING / TECHNOLOGY SYLLABUS
N - SCHEME

(To be implemented for the students admitted from the year 2020 - 2021 onwards)

Course Name : 1020 Diploma in Mechanical Engineering

Subject Code : 4020410

Semester : IV

Subject Title : Fluid Mechanics and Fluid Power

TEACHING AND SCHEME OF EXAMINATION

No of weeks per semester: 16 weeks

Subject	Instructions		Examination			
	Hours / Week	Hours / Semester	Marks			Duration
Internal Assessment			Board Examinations	Total		
4020410 Fluid Mechanics and Fluid Power	5	80	25	100*	100	3 Hrs.

* Examinations will be conducted for 100 marks and it will be reduced to 75 marks for result.

Topics and Allocation of Hours

Unit No	Topics	Hours
I	Properties of Fluids & Fluid Pressure	12
II	Fluid Flow, Flow Through Pipes & Impact of Jet	17
III	Hydraulic Turbines, Centrifugal Pumps & Reciprocating Pumps	16
IV	Hydraulic Systems	16
V	Pneumatic Systems	12
Test and Model Exam		7
Total		80

RATIONALE:

The purpose of this subject is to teach the students the fundamentals of engineering fluid mechanics in a very general manner so that they can understand the way that forces are produced and transmitted by fluids that are, first, essentially at rest and, second, in motion. This will allow them to apply the physical principles behind some of the most common applications of fluid mechanics in engineering.

OBJECTIVES:

- To study the basic fluid properties and types of flow;
- To understand the transmission of pressure in liquids and its application to hydraulics;
- To calculate hydrostatic forces on plane and curved submerged surfaces;
- To employ the concept of continuity of flow and use Bernoulli's equation to measure flow rate and velocity;
- To apply the momentum principle to liquids in jets and pipes.
- To understand the working of hydraulic machines like, turbines, pumps.
- To identify the various components of a Hydraulic & Pneumatic systems and select them for design of hydraulic and pneumatic circuits for Engineering applications.

4020410 FLUID MECHANICS AND FLUID POWER DETAILED SYLLABUS

Contents: Theory

Unit	Name of the Topics	Hours
I	PROPERTIES OF FLUIDS & FLUID PRESSURE Chapter: 1.1: Properties of Fluids Fluid – definition-classification. Properties – density, specific gravity, specific weight, specific volume, dynamic viscosity, kinematic viscosity, surface tension, capillarity, vapour pressure and compressibility – Problems	4
	Chapter: 1.2: Fluid Pressure & Its Measurement Fluid Pressure – Hydrostatic law - Pressure head, Pascal's Law – proof -	8

	<p>applications - Hydraulic press- Hydraulic jack. Concepts of absolute, vacuum, gauge and atmospheric pressures.</p> <p>Pressure measurements – Simple U tube manometers and differential manometers and their types – Problems - Bourdon tube pressure gauge.</p> <p>Pressure sensor technologies - classification only.</p> <p>Total Pressure, Centre of pressure on immersed bodies (flat vertical., flat vertical) – Problems.</p>	
II	<p>FLUID FLOW, FLOW THROUGH PIPES & IMPACT OF JET</p> <p>Chapter: 2.1: Fluid Flow</p> <p>Types of Fluid flow - Laminar, turbulent, steady, unsteady, uniform, non-uniform, rotational, irrotational. Continuity equation, Bernoulli's theorem - assumptions- derivation - applications and limitations - Problems.</p> <p>Venturimeter – Construction - working principle, coefficient of discharge - derivation for discharge. Orificemeter - Construction working principle, coefficient of discharge- derivation for discharge. Problems. Pitots Tube – Construction and working principle only.</p> <p>Chapter: 2.2: Flow through Pipes</p> <p>Laws of fluid friction for Laminar and turbulent flow- Darcy's equation and Chezy's equation for frictional losses – Problems. Minor Losses - description. Hydraulic gradient line and Total energy line. Hydraulic Power transmission through pipes – problems.</p> <p>Chapter: 2.3: Impact of Jet</p> <p>Impact of jet on fixed vertical plate - Impact of jet on moving vertical flat plates in the direction of jet - Impact of jet on a series of moving plates or vanes - Problems on work done and efficiency.</p>	<p>6</p> <p>6</p> <p>5</p>
III	<p>HYDRAULIC TURBINES, CENTRIFUGAL PUMPS & RECIPROCATING PUMPS</p> <p>Chapter: 3.1: Hydraulic Turbines</p> <p>Classification of hydraulic turbines and their applications. Construction and working principle of Pelton wheel, Francis and Kaplan turbine. Draft tubes – types and construction, Concept of cavitation in turbines, Surge tank and its need.</p>	4

	<p>Chapter: 3.2: Centrifugal Pumps</p> <p>Construction - Principle of working. Types of casings and impellers. Concepts of multistage. Priming and its methods. Manometric head, work done, manometric, mechanical and overall efficiencies - problems</p> <p>Chapter: 3.3: Reciprocating Pumps</p> <p>Construction, working principle and applications of single and double acting reciprocating pumps. Discharge - Theoretical power required coefficient of discharge – Problems</p> <p>Concepts of slip – negative slip. Cavitation and separation. Use of air vessel. Indicator diagram with effect of acceleration head and friction head.</p>	6
IV	<p>HYDRAULIC SYSTEMS</p> <p>Chapter: 4.1: Introduction to Fluid power systems</p> <p>Fluid power systems - general layout - components of hydraulic & Pneumatic systems. Practical applications of Fluid power systems. Comparison - Advantages and limitations.</p> <p>Chapter: 4.2: Components of Hydraulic systems</p> <p>Types, construction, working Principle and symbol of the following components. Pump – vane, gear and piston pumps. Valves: Pressure Control valves – pressure relief . valve, pressure reducing valve, pressure unloading valve. Direction control valve – poppet valve, spool valve, 3/2, 4/2 & 4/3 DC valves, sequencing valve. Flow control valve – pressure compensated – non pressure compensated. Actuators – Linear actuators – single acting & double acting – rotary actuators – hydraulic motors. Accessories – Intensifiers and Accumulators.</p> <p>Chapter: 4.3: Hydraulic Circuits</p> <p>Double acting cylinder with Meter in, Meter out circuits, Pump unloading cut, Bleed off circuit, sequencing circuit. Hydraulic circuits for milling machine, shaping machine. Motion synchronisation circuit.</p>	4 8 4
V	<p>PNEUMATIC SYSTEMS</p> <p>Chapter: 5.1: Components of pneumatic systems</p> <p>Types, construction, working Principle and symbol of the following components. Compressor – Reciprocating & Rotary Compressors.</p>	8

	<p>Valves. Pressure Control valves – pressure relief valve, pressure regulating valves. Direction control valves – 3/2, 5/2 & 5/3 DC valves, sequencing valve. Flow control valve – throttle valves – shuttle valves- quick exhaust valves. Actuators – Linear actuators – single acting & double acting – rotary actuators – air motors. Accessories.- FRL unit.</p> <p>Chapter: 5.2: Pneumatic Circuits</p> <p>Double acting cylinder with Meter in, Meter out circuits, speed control circuit and sequencing circuit</p>	4
--	--	---

Reference Books:

1. A Textbook of Fluid Mechanics and Hydraulic Machines, R. K. Bansal, Laxmi Publications (P).,Ltd, New Delhi, 2010
2. Hydraulics and Fluid Mechanics, Modi P.N. and Seth, S.M. Standard Book House, New Delhi, 2013.
3. Fluid Power with Applications, Anthony Esposito., Pearson Education 2005.
4. A Textbook of Fluid Mechanics, R. K Rajput, S.Chand & Co, New Delhi, 2019
5. Engineering Fluid Mechanics, Kumar K. L., Eurasia Publishing House (P) Ltd., New Delhi, 2016.
6. Oil Hydraulics Systems- Principles and Maintenance”, Majumdar S.R., Tata McGraw- Hill, 2001.
7. Hydraulic and Pneumatic Controls, Shanmugasundaram.K, Chand & Co, 2006

Blank page

STATE BOARD OF TECHNICAL EDUCATION & TRAINING, TAMILNADU
DIPLOMA IN ENGINEERING / TECHNOLOGY SYLLABUS
N - SCHEME

(To be implemented for the students admitted from the year 2020 - 2021 onwards)

Course Name : 1020 Diploma in Mechanical Engineering
 Subject Code : 4020420
 Semester : IV
 Subject Title : Manufacturing Technology - II

TEACHING AND SCHEME OF EXAMINATION

No of weeks per semester: 16 weeks

Subject	Instructions		Examination			
	Hours / Week	Hours / Semester	Marks			Duration
Internal Assessment			Board Examinations	Total		
4020420 Manufacturing Technology - II	5	80	25	100*	100	3 Hrs.

* Examinations will be conducted for 100 marks and it will be reduced to 75 marks for result.

Topics and Allocation of Hours

Unit No	Topics	Hours
I	Theory of Metal Cutting, Drilling Machine & Abrasive Process	15
II	Reciprocating Machines and Broaching	15
III	Milling Machines and Gear Generating	14
IV	Unconventional Machining Processes	14
V	CNC Machine and CNC Programming	15
Test and Model Exam		7
Total		80

	<p>drilling machines – bench type – floor type – radial type – gang drill – multi spindle type – principle of operation in drilling – methods of holding drill bit – drill chucks – socket and sleeve – drilling operation – reaming, counter sinking, counter boring, spot facing, tapping and deep hole drilling.</p> <p>Chapter: 1.3: Abrasive process</p> <p>Types and classification – specifications – rough grinding – pedestal grinders - portable grinders – belt grinders. Precision grinding – cylindrical grinder – centerless grinders - surface grinder – tool and cutter grinder – planetary grinders – principles of operations – grinding wheels – abrasives – natural and artificial diamond wheels – types of bonds – grit, grade and structure of wheels – wheel shapes and sizes – standard marking systems of grinding wheels – selection of grinding wheel – mounting of grinding wheels – dressing and truing of wheels – balancing of grinding wheels.</p>	7
II	<p>RECIPROCATING MACHINES</p> <p>Chapter: 2.1: Planer</p> <p>Introduction – description of double housing planer – specifications – principles of operation – drives – quick return mechanism – feed mechanism - operations.</p> <p>Chapter: 2.2: Shaper</p> <p>Introduction – specifications – principles of operations – standard shaper – quick return mechanism – crank and slotted link – hydraulic shaper – feed mechanism – operations.</p> <p>Chapter: 2.3: Slotter</p> <p>Introduction - specifications – method of operation – whitworth quick return mechanism - feed mechanism – types of tools.</p> <p>Chapter: 2.4: Broaching</p> <p>Types of broaching machine – horizontal, vertical and continuous broaching – principles of operation – types of broaches – classification – broach tool nomenclature – broaching operations.</p>	4 4 3 4

<p>III</p>	<p>MILLING MACHINES AND GEAR GENERATING PROCESSES</p> <p>Chapter: 3.1: Milling machines</p> <p>Types – column and knee type, plain, vertical and universal milling machines – principles of operation – specification of milling machines – work holding devices – tool holding devices – arbor – stub arbor – spring collet – adaptor. Milling cutters – cylindrical milling cutter - slitting cutter – side milling cutter – angle milling cutter – T slot milling cutter – woodruff milling cutter – fly cutter – nomenclature of cylindrical milling cutter. Milling operations – straddle milling - gang milling – vertical milling attachment. Indexing plate – differential indexing – simple indexing and compound indexing – simple problems.</p> <p>Chapter: 3.2: Generating processes</p> <p>Gear shaper – gear hobbing – principle of operations only. Gear finishing processes – burnishing – shaving – grinding and lapping – gear materials.</p>	<p>10</p> <p>4</p>
<p>IV</p>	<p>UNCONVENTIONAL MACHINING PROCESSES</p> <p>Chapter: 4.1: Mechanical energy based process</p> <p>Introduction – classification – process selection – advantages – limitations – demerits of conventional processes. Mechanical energy based process: Introduction – abrasive jet machining – metal removal rate process parameters – water jet machining – hydrodynamic jet machining – ultrasonic machining process – advantages – disadvantages – applications – compare ultrasonic machining with traditional abrasive machining.</p> <p>Chapter: 4.2: Electrical energy based processes</p> <p>Introduction – electrical discharge machine (EDM) – flushing system in EDM – tool (electrode) materials - tool wear – metal removal rate and surface finish - factors affecting the metal removal rate – advantages – disadvantages – applications – wire cut EDM , features of wire cut EDM – difference between EDM and wire cut EDM.</p> <p>Chapter: 4.3: Thermal energy based processes</p> <p>Introduction – electron beam machining – laser beam machining – lasing materials – machining applications of laser – plasma arc machining –</p>	<p>5</p> <p>5</p> <p>4</p>

	gases used in plasma arc machining – types of plasma arc torches – advantages – disadvantages – applications.	
V	<p>CNC MACHINE AND ITS COMPONENTS</p> <p>Chapter: 5.1: CNC machines</p> <p>Numerical control – definition – working principle of a CNC system – features of CNC machines – advantages of CNC machines – difference between NC and CNC – construction and working principle of turning centre – construction and working principle of machining centre - machine axes conventions turning centre and machining centre – co-ordinate measuring machine – construction and working principle.</p> <p>Chapter: 5.2: Components of CNC machine</p> <p>Slide ways – requirement – types – friction slide ways and anti-friction slide ways – linear motion bearing – recirculation ball screw – ATC – tool magazine – feedback devices – linear and rotary transducers – encoders – in process probing – tool material – tool inserts.</p> <p>Chapter: 5.3: CNC Programming</p> <p>Introduction – Cartesian coordinate system – Polar coordinate system – Absolute and incremental positioning – Purpose of G and M codes. Basic codes – basic CNC program. CNC turning program using linear interpolation and circular interpolation. Machine control panel – Homing position – Offset setting – Auto. CNC milling program using linear interpolation and circular interpolation. Compensation – Machine control panel – Home position – Work offset setting procedure – Tool offset .</p>	<p>5</p> <p>4</p> <p>6</p>

Reference Book:

1. Elements of Workshop Technology- Vol. I & II, Hajra Choudry & Battacharya, Edn. 11, published by Media Promoters and Publishers Pvt. Ltd., Seervai Buildings `B', 20-G, Noshir Bharucha Marg, Mumbai 400 007 – 2007.
2. Production Technology, Jain & Gupta, Khanna Publishers, 2-B, North Market, Naisarak, New Delhi – 110 006 – 2006.
3. Production Technology, HMT, Edn. 18, published by Tata McGraw Hill Publishing Co. Ltd., 7, West Patel Nagar, New Delhi 110 008.

4. Manufacturing process, Myro N Begman, , Edn. 5, Tata McGraw Hill Publishing Co. Ltd., 7, West Patel Nagar, New Delhi 110 008.
5. Workshop Tech Vol I,II, III, WAJ. Chapman, published by Viva Books Pvt. Ltd., 4262/3, Ansari Road, Daryaganj, New Delhi 110 002.
6. Production processes, NITTTTR, published by 5, Tata McGraw Hill Publishing Co. Ltd., West Patel Nagar, New Delhi 110 008.
7. Principles of the manufacturing of Composite materials – Suong V Hoa, DES tech publication. Inc, 439, North Duke street, Lancaster, Pennsylvania – 17602 U.S.A.

STATE BOARD OF TECHNICAL EDUCATION & TRAINING, TAMILNADU
DIPLOMA IN ENGINEERING / TECHNOLOGY SYLLABUS
N – SCHEME

(To be implemented for the students admitted from the year 2020 – 2021 onwards)

Course Name : 1020 Diploma in Mechanical Engineering
 Subject Code : 4020430
 Semester : IV
 Subject Title : Electrical Drives and Control

TEACHING AND SCHEME OF EXAMINATION

No of weeks per semester: 16 weeks

Subject	Instructions		Examination			
	Hours / Week	Hours / Semester	Marks			Duration
Internal Assessment			Board Examinations	Total		
4020430 Electrical Drives and Control	5	80	25	100*	100	3 Hrs.

* Examinations will be conducted for 100 marks and it will be reduced to 75 marks for result.

Topics and Allocation of Hours

Unit No	Topics	Hours
I	Dc Circuits and Dc Machines	15
II	Ac Circuits and Ac Machines	15
III	Special Machines & Drives	15
IV	Power Supplies, Control Elements and Electrical Safety	14
V	Display Devices, Logic Gates and PLC	14
Test and Model Exam		7
Total		80

RATIONALE:

The automation is being the order of the day to improve the production with high quality consciousness. Such automation involves electrically operated switches, sensors controlled through electrically driven motors and actuators. The subject aims in introducing the basic electrical DC and AC circuits and motors and also focuses on the various special control devices like stepper, servo drives and its controlling elements.

OBJECTIVES:

- Explore fundamental electric circuit laws.
- Explain the working principle of DC and AC Electrical machines.
- Identify the effective uses of drives of Electrical machines.
- Analyze the various power supply circuits.
- Select the field controlled elements.
- Explain the construction and working of Transformer.
- Compare the different types of Logic gates.
- Appreciate the safety practices followed in Electrical system.
- Compare the use of servo motors and stepper motors in electrical driving system
- Identify PLC Input outputs.
- Identify the use of Control elements.

4020430 ELECTRICAL DRIVES AND CONTROL DETAILED SYLLABUS

Contents: Theory

Unit	Name of the Topics	Hours
I	DC CIRCUITS AND DC MACHINES <u>Chapter: 1.1:</u> Definition- Electric Current, Voltage and Resistance -Ohm's law and Kirchoff's law. Resistance in series, parallel and series parallel – simple problems - Electromagnetism (definitions only) – Magnetic flux, Fluxdensity, Magnetic field intensity, MMF, Permeability,	7

	<p>Reluctance, Faraday's law of Electromagnetic induction, Electrical and Mechanical units.</p> <p><u>Chapter: 1.2:</u></p> <p>DC Generators – Construction, Principle of operation and Applications. DC Motors: - Construction, Principle of operation and Applications.</p> <p>Necessity of starters: Three point, four point starters.</p>	8
II	<p>AC CIRCUITS AND AC MACHINES</p> <p><u>Chapter: 2.1:</u></p> <p>Fundamentals of AC voltage, and current – Peak, Average, RMS value of sine wave, frequency, time period, amplitude, power and power factor (definition only).</p> <p>Transformer: Principle of operation and construction – EMF equation - Losses in Transformer – Efficiency – Applications.</p> <p>Alternator construction – Principle of operation and Applications.</p> <p><u>Chapter: 2.2:</u></p> <p>AC machine: AC Motors- Principle of operation of Single Phase, Capacitor Start induction motor - universal motor - Applications- Three Phase Induction Motors – Squirrel Cage and Slip ring Induction motors (Construction and Working Principle only) - Applications – Speed control of 3Φ Induction Motor - DOL and star/delta starter.</p>	7 8
III	<p>SPECIAL MACHINES & DRIVES</p> <p><u>Chapter: 3.1:</u></p> <p>PMDC Motor, Stepper motor- Construction and Working Principle and Applications - Servo motor – types.</p> <p>Permanent Magnet Servo motor Construction and Applications.</p> <p>Brushless Servo motor - Construction and Applications.</p> <p><u>Chapter: 3.2:</u></p> <p>Industrial drives- types, Group drive, Individual drive, Multi motor drive. Block diagram of Variable Frequency Drive (VFD).</p> <p>Stepper motor Drive: Single stepping and Half stepping Servo drives.</p> <p>DC Servo drive, AC Servo drive and BLDC Servo drive.</p>	7 8

IV	POWER SUPPLIES, CONTROL ELEMENTS AND ELECTRICAL SAFETY	
	<u>Chapter: 4.1:</u> Rectifiers – Half wave, Full wave and Bridge rectifiers – Necessity of Filters- Regulated Power Supplies: IC Voltage Regulators. Batteries - Working, Constructions, Maintenances and Trouble shooting.	5
	<u>Chapter: 4.2:</u> Fuses – Selection of Fuse – Necessity of Fuse- Fuse switch units. Sensors: Photo electric sensor, Inductive Proximity sensors, Temperature sensors. Contactors - usage – Necessity of Contactor- Solenoid type Contactor.	5
	<u>Chapter: 4.3:</u> Circuit breakers – Miniature Circuit Breaker (MCB), Earth Leakage Circuit Breaker (ELCB). Electrical Safety: - Importance of Earthing - Electric shock: First aid, Precautions - Causes of Accident and their Preventive measures.	4
V	DISPLAY DEVICES, LOGIC GATES AND PLC	
	<u>Chapter: 5.1:</u> Display devices – LED, 7 segments LED, LCD, applications.	4
	<u>Chapter: 5.2:</u> Logic gates: Positive and Negative Logic, Definition, Symbol and truth table. Boolean expression for OR, AND, NOT, NOR, NAND, EXOR AND EXNOR gates. Universal Logic Gates: NAND, and NOR.	5
	<u>Chapter: 5.3:</u> Features of PLC - PLC Block diagram - PLC scan. Fixed and Modular PLC. Ladder logic - NO, NC contacts - Coils - AND logic, OR logic.	5

Reference Books

1. Fundamentals of physics, Brijlal and Subramaniam.
2. Fundamentals of Electricity, D.N. Vasudeva, S. Chand & co.
3. Electric motors and drives, Austin Hughes
4. A text book of Electrical Technology, Volume II, B.L. Theraja, S. Chand & co.
5. Programmable Logic Controllers – John R Hackworth Frederick D. Hackworth Jr., Pearson Education.

STATE BOARD OF TECHNICAL EDUCATION & TRAINING, TAMILNADU
DIPLOMA IN ENGINEERING / TECHNOLOGY SYLLABUS
N-SCHEME

(To be implemented for the students admitted from the year 2020 - 2021 onwards)

Course Name : 1020 Diploma in Mechanical Engineering

Subject Code : 4020440

Semester : IV

Subject Title : Production and Quality Management

TEACHING AND SCHEME OF EXAMINATION

No of weeks per semester: 16 weeks

Subject	Instructions		Examination			Duration
	Hours / Week	Hours / Semester	Marks			
Internal Assessment			Board Examinations	Total		
4020440 Production and Quality Management	5	80	25	100*	100	3 Hrs.

* Examinations will be conducted for 100 marks and it will be reduced to 75 marks for result.

Topics and Allocation of Hours:

Unit No	Topics	Hours
I	Process Planning and Selection	15
II	Basic concepts of Total Quality Management	14
III	TQM Tools	14
IV	Statistical Fundamentals & Charts	15
V	Lean Manufacturing Concepts	15
Test and Model Exam		07
Total		80

RATIONALE:

In the product manufacturing the process selection and planning are important. Quality and customer satisfaction in every product and every activity is the order of the day. As there is a shift from quality control to quality management in all activities, the concept Total Quality Management and the pillars of TQM are to be given to Engineers, who are designing products and production systems.

OBJECTIVES:

- Understand the process planning.
- Study the process selection.
- Define quality and appreciate its signature.
- Explain the concept of TQM.
- Appreciate the use of principles of TQM to meet customer satisfaction.
- Solve problem using the Quality control tools.
- Apply Brainstorming and quality circle to solve problems.
- Use PDCA cycle for continuous improvement.
- Appreciate the benefits of implementing 5S concepts.
- Collect, classify and present the data.
- Determine the process capability of a manufacturing process.
- Practice on management planning tools.
- Use Bench Mark and JIT concepts.

4020440 PRODUCTION AND QUALITY MANAGEMENT DETAILED SYLLABUS

Contents: Theory

Unit	Name of the Topic	Hours
I	Process Planning And Selection	
	Chapter: 1.1: Production: Types of Production – Mass production, batch production and job order production	3
	Chapter: 1.2: Process Planning: Introduction – concept – Information required to do processplanning – factors affecting process planning – process	6

	<p>planning procedure – Make (or) Buy decision using Break Even Analysis – simple problems. Manual process planning – Introduction of Automated process planning and generator process planning – Advantage of computer aided process planning – Principle of line balancing – need for line balancing – Value Engineering – Definition – cost control Vs cost reduction – value analysis when to do – steps information needed – selection of product.</p> <p>Chapter: 1.3:</p> <p>Process Selection: Process selection – technological choice – specific component choice – Process flow choice – Factors affecting process selection – machine capacity – analysis of machine capacity – process and equipment selection procedure – Determination of man, machine and material requirements – simple problems – selection of material – jigs – fixtures etc. – Factors influencing choice of machinery – selection of machinery – simple problems – Preparation of operation planning sheet for simple components.</p>	6
II	<p>Chapter: 2.1: Basic Concepts Of Total Quality Management</p> <p>Quality-Definitions – Dimensions of quality – Brainstorming and its objectives – Introduction to TQM - Characteristics – Basic concepts – Elements - Pillars – Principles – Obstacles to TQM implementation - Potential benefits of TQM - Quality council – duties – Responsibilities - Quality statements – Vision – Mission – Quality policy statements – Strategic planning – Seven steps to strategic planning – Deming philosophy – Customer – Input / Output process model – Juran Trilogy - PDCA (Deming Wheel) cycle.</p>	14
III	<p>TQM Tools</p> <p>Chapter: 3.1:</p> <p>Seven tools of quality control (Q 7 tools): Check sheet – Types of check sheet – Histogram – Cause and effect diagram – Pareto diagram – Stratification Analysis – Scatter diagram-Graph/run charts – Control charts – Construction of above diagrams. Quality circle – concept of quality circle – Organisation of Quality circle and objectives of Quality circle. Zero Defect Concepts.</p>	14

	<p>Chapter: 3.2: Management Planning Tools (M 7 Tools) Affinity diagram – Radar Diagram – Inter Relationship diagram (Inter Relationship diagram) – Tree diagram – Prioritization matrix – Matrix diagram – Decision tree – Arrow diagram – Matrix data analysis diagram – Construction of above diagrams.</p>	
IV	<p>Statistical Fundamentals And Control Charts Chapter: 4.1: Types of Data – Collection of Data – Classification of Data – Tabular presentation of Data - Graphical representation of a frequency distribution – Comparison of Frequency distribution – Mean - Median – Mode – Comparison of measures of central tendency - Introduction to measures of dispersion – Sample – sampling – Normal curve – Sigma – Concept of six sigma – Principles – Process - Problems.</p> <p>Chapter: 4.2: Control Charts Control chart – Types of control charts – Control chart for variables – Construction of X bar and R charts – control limits Vs specification limits – Process capability – Method of doing process capability Analysis – Measures of process capability – Problems. Attributes – Control charts - P chart – np chart – c chart – u chart – Construction of above diagrams – Problems – Comparison between variable chart and Attribute chart.</p>	<p>7</p> <p>8</p>
V	<p>Capter 5.1: Lean Manufacturing Concepts 5S Concepts (SEIRI, SEITON, SEISO, SEIKETSU and SHITSUKE) – needs and objectives – effective implementation of 5S concepts in an organisation – Housekeeping – Kaizen – Kanban System. Bench marking - Objectives of bench marking – Types – Benchmarking process – Benefits of Bench marking – Pit falls of Benchmarking-Just In Time(JIT) concepts and its objectives – TotalProductive Maintenance(TPM) – Introduction, Objectives of TPM –steps in implementing TPM. – Overall Equipment Effectiveness(OEE)–Lean Six Sigma – Value Stream Mapping – DMAIC(Define, Measure, Analyse, Improve, Control) – DMADV (Define , Measure, Analyse, Design, Verify)</p>	15

Reference Books:

1. Industrial Engineering & Management – O.P Khanna
2. Industrial Engineering & Production Management – Martand Telsang
3. Total Quality Management, Date H.Besterfiled, Pearson Education Asia.
4. Total Quality Management, V.Jayakumar, Lakshmi Publications.(reprint 2005)
5. Training manual on ISO 9001 : 2000 & TQM, Girdhar J.Gyani, Raj PublishingHouse, Second Edition 2001
6. Quality Management, Howard Cuitlow, Tata Mc Graw Hill, 1998
7. Production Engineering – P.C.Sharma.
8. Production and Costing – GBS Narang and V.Kumar
9. Mechanical Estimating and Costing – Banga & Sharma.
- 10.Total Quality Management, Oakiand.J.S. Butterworth Heinemann Ltd. Oxford1989.
- 11.Quality Management – Concepts and Tasks- Narayana.V and
- 12.Sreenivasan.N.S., New Age International 1996.
- 13.Total Quality Management for engineers, Zeiri. Wood Head Publishers. 1991.
- 14.Quality Planning and Analysis, Juran J.M and Frank M.Gryna Jr., TMH. India.1982
- 15.ISO 9001, Brain Rethry, Productivity and Quality Publications.
- 16.ISO 9001, Brain Rethry, Productivity and Quality Publishing Pvt. Ltd. 1993.
- 17.Quality Auditing D.Mills, Chapman and Hall, 1993.

Blank Page

**STATE BOARD OF TECHNICAL EDUCATION & TRAINING, TAMILNADU
DIPLOMA IN ENGINEERING / TECHNOLOGY SYLLABUS**

N – SCHEME

(To be implemented for the students admitted from the year 2020 – 2021 onwards)

Course Name : 1020 Diploma in Mechanical Engineering
 Subject Code : 4020450
 Semester : IV
 Subject Title : Strength of Materials and Fluid Mechanics Practical

TEACHING AND SCHEME OF EXAMINATION

No of weeks per semester: 16 weeks

Subject	Instructions		Examination			
	Hours / Week	Hours / Semester	Marks			Duration
Internal Assessment			Board Examinations	Total		
4020450 Strength of Materials and Fluid Mechanics Practical	4	64	25	100*	100	3 Hrs.

* Examinations will be conducted for 100 marks and it will be reduced to 75 marks for result.

OBJECTIVES:

- Acquire skills on different types of testing methods of metals.
- Conduct material testing on elasticity, hardness, shear strength
- Determine modulus of rigidity of open coil spring and closed coil springs.
- Determine the co-efficient of discharge of venturimeter and mouth piece
- Determine the co-efficient of friction in pipes.
- Conduct performance test on reciprocating pump.
- Conduct performance test on impulse turbine.

4020450 STRENGTH OF MATERIALS AND FLUID MECHANICS PRACTICAL DETAILED SYLLABUS

Experiments:

PART A : Strength of Materials Laboratory

1. Test on Ductile Materials:

Finding Young's Modulus of Elasticity, yield points, percentage elongation and percentage reduction in area, stress strain diagram plotting, tests on mild steel.

2. Hardness Test:

Determination of Rockwell's Hardness Number for various materials like mild steel, high carbon steel, brass, copper and aluminium.

3. Torsion test:

Torsion test on mild steel – relation between torque and angle of twist- determination of shear modulus and shear stress.

4. Impact test:

Finding the resistance of materials to impact loads by Izod test and Charpy test.

5. Tests on springs of circular section:

Determination of modulus of rigidity, strain energy, shear stress and stiffness by load deflection method (Open or Closed coil spring)

6. Shear test:

Single or double shear test on M.S. bar to finding the resistance of material to shear load.

PART B: Fluid Mechanics Laboratory

1. Verify the Bernoulli's Theorem.

2. Determination of co-efficient of discharge of a mouth piece by variable head method.

3. Determination of co-efficient of discharge of a venturimeter.

4. Determination of the friction factor in a pipe.

5. Performance test on reciprocating pump and to draw the characteristics curves.

6. Performance test on impulse turbine and to find out the Efficiency.

BOARD EXAMINATION

Note:

- All the experiments in both sections have to be completed. Two experiments will be given for examination by selecting one exercise from PART A and one exercise from PART B.
- All the experiments should be given in the question paper and students are allowed to select by a lot or Question paper issued from the DOTE should be followed.
- All regular students appearing for first attempt should submit record notebook for the examination.
- The external examiner should verify the availability of the facility for the batch strength before commencement of practical examination.
- The external examiner should verify the working condition of machinery's / equipment before commencement of practical examination.

DETAILED ALLOCATION OF MARKS

Part-A	:	45 marks
Procedure / Observation	10	
Tabulation / Calculations	25	
Result / Graph	10	
Part-B	:	45 marks
Procedure / Observation	10	
Tabulation / Calculations	25	
Result / Graph	10	
Viva-voce	:	10 marks
Total	:	100 Marks

LIST OF EQUIPMENTS: (For 30 students)

1. UTM.	01
2. Rockwell's Hardness Testing Machine.	01
3. Torsion testing machine.	01
4. Impact testing machine.	01
5. Spring testing arrangements.	01
6. Shear testing machine.	01
7. Vernier calliper.	02
8. The Bernoulli's Apparatus.	01
9. An open tank fitted with an external mouth piece and a collecting tank with Piezometer.	01
10. An arrangement to find friction factor of pipe.	01
11. A reciprocating pump with an arrangement for collecting data to find out the efficiency and plot the characteristics curves.	01
12. A impulse turbine with an arrangement for calculating data to find out the efficiency.	01
13. An arrangement of Venturimeter fitted in horizontal water pipe line to find coefficient of discharge.	01

STATE BOARD OF TECHNICAL EDUCATION & TRAINING, TAMILNADU
DIPLOMA IN ENGINEERING / TECHNOLOGY SYLLABUS
N - SCHEME

(To be implemented for the students admitted from the year 2020 - 2021 onwards)

Course Name : 1020 Diploma in Mechanical Engineering
 Subject Code : 4020460
 Semester : IV
 Subject Title : Manufacturing Technology - II Practical

TEACHING AND SCHEME OF EXAMINATION

No of weeks per semester: 16 weeks

Subject	Instructions		Examination			
	Hours / Week	Hours / Semester	Marks			Duration
Internal Assessment			Board Examinations	Total		
4020460 Manufacturing Technology - II Practical	4	64	25	100*	100	3 Hrs.

* Examinations will be conducted for 100 marks and it will be reduced to 75 marks for result.

OBJECTIVES:

- Identify a milling machine and its parts
- Identify a cylindrical grinder, surface grinder and tool and cutter grinder
- Identify shaper, Slotter and its parts
- Identify the tools and instruments used in milling.
- Study the components of the CNC machine and setting.
- Handle the different types of work holding devices
- Machine a component using different machine tools.
- Calculate the indexing for a work
- Machine a gear using milling machine.
- Machine a cutting tool using Tool and Cutter grinder.
- Machine a plug gauge using Cylindrical grinding machine.
- Machine components by shaping machine
- Machine components by slotting machine.
- Machine components by the CNC machines.

**4020460 MANUFACTURING TECHNOLOGY - II PRACTICAL
DETAILED SYLLABUS**

EXERCISES:

Raw Material: M.S. / C.I

1. Make 'V' Block using shaping machine

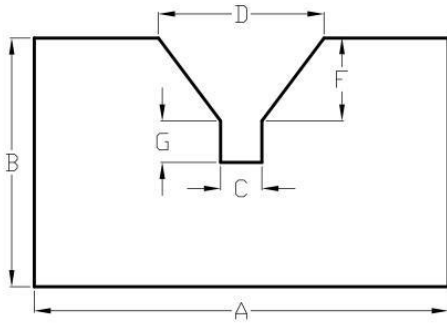

Dimensions			
Sl.No	Part Name	Actual	Obtained

2. Make dovetail using shaping machine

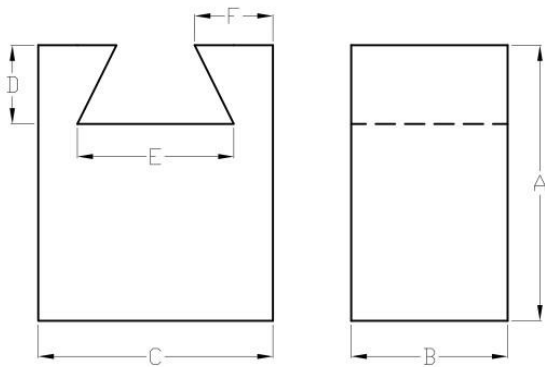

Dimensions			
Sl.No	Part Name	Actual	Obtained

3. Make groove cut using slotting machine

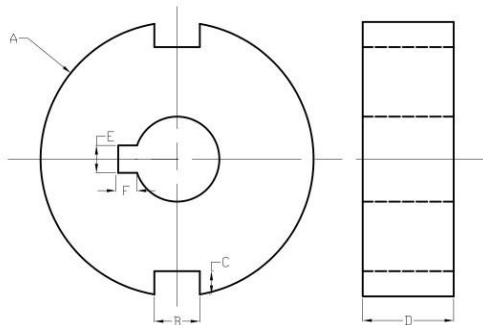

Dimensions			
Sl.No	Part Name	Actual	Obtained

4. Make round to hexagon in milling machine.

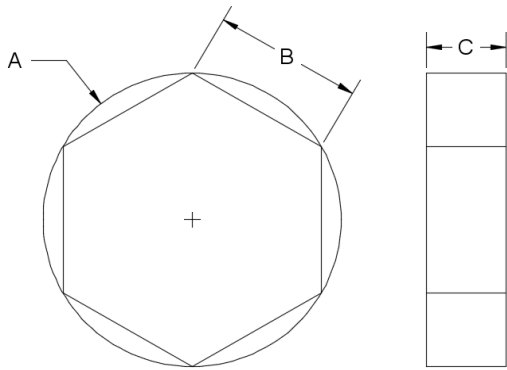

Dimensions			
Sl.No	Part Name	Actual	Obtained

5. Make Spur Gear using milling machine.

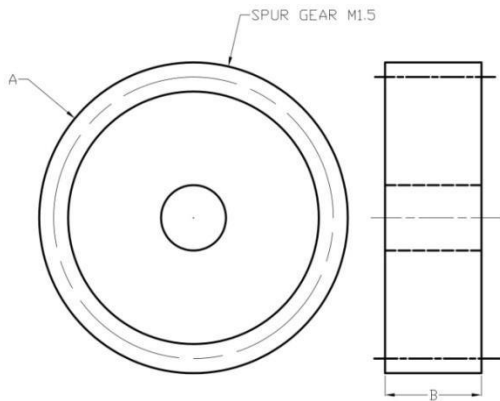

Dimensions			
Sl.No	Part Name	Actual	Obtained

6. Make Helical Gear using milling machine.

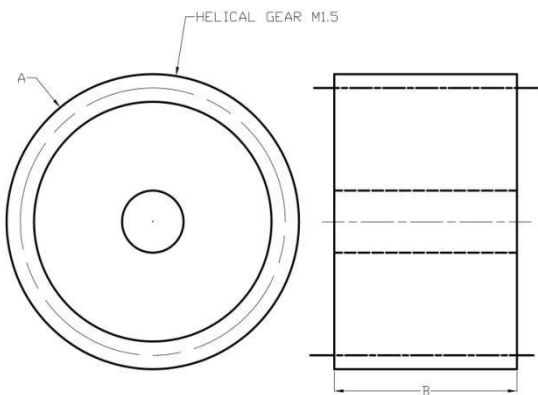

Dimensions			
Sl.No	Part Name	Actual	Obtained

7. Make slot cut using milling machine.

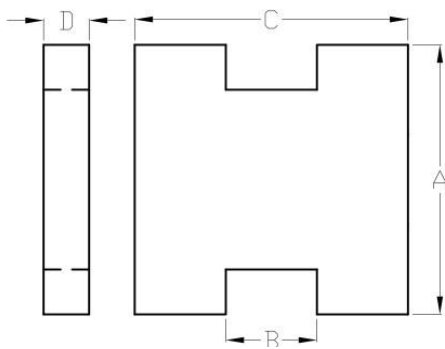

Dimensions			
Sl.No	Part Name	Actual	Obtained

8. Make Progressive type Plug gauge using Cylindrical Grinding machine

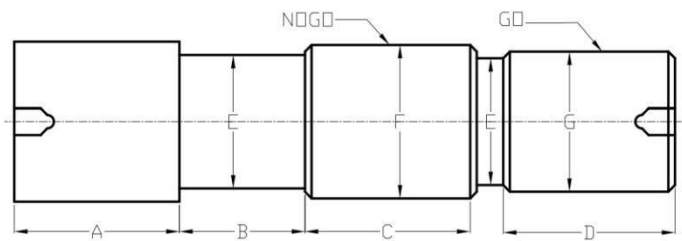

Dimensions			
Sl.No	Part Name	Actual	Obtained

9. Make a turning tool using Tool and Cutter Grinder

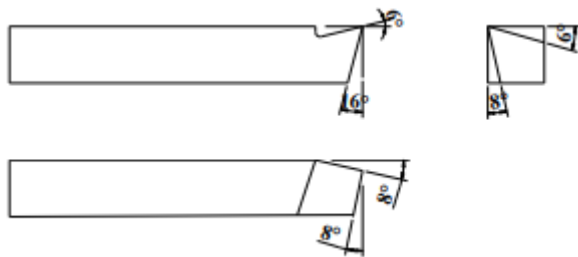

Dimensions			
Sl.No	Part Name	Actual	Obtained

10. Make plain surfaces (four surfaces) using surface Grinder

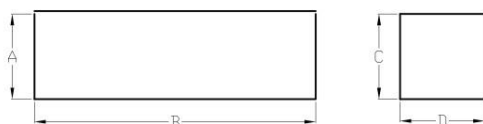

Dimensions			
Sl.No	Part Name	Actual	Obtained

11. Make the component in the CNC Tuming Centre.

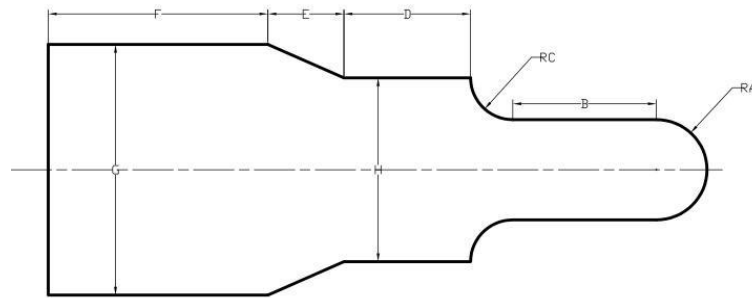

12. Make the component in the CNC Milling Centre.

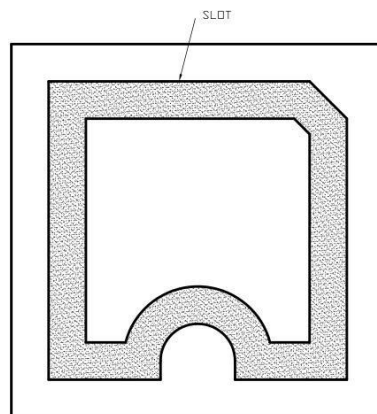

BOARD EXAMINATION

Note:

- All the exercises should be completed. Any one exercise will be given for examination.
- All the exercises should be given in the question paper and students are allowed to select by a lot or Question paper issued from the DOTE should be followed.
- All regular students appearing for first attempt should submit record notebook for the examination.
- The external examiner should verify the availability of the facility for the batch strength before commencement of practical examination.
- The external examiner should verify the working condition of machinery's / equipment before commencement of practical examination.

DETAILED ALLOCATION OF MARKS

Description	Marks
Procedure	10
Preparation of the Specimen	15
Setting and Machining	30
Dimensions	25
Finishing	10
Viva-voce	10
Total	100

LIST OF EQUIPMENTS (For 30 students)

1	Vertical milling machine / Vertical attachment	-	2 Nos.
2.	Universal Milling Machine	-	2 Nos.
3.	Surface Grinding Machine	-	1 No.
4.	Cylindrical Grinding Machine	-	1 No.
5.	Tool and Cutter Grinder	-	1 No.
6.	Shaping Machine	-	2 Nos.
7.	Slotting Machine	-	1 No.
8.	CNC Turning centre	-	1 No.
9.	CNC Milling Centre	-	1 No.
10	Tools and Measuring instruments	-	Sufficient quantity.
11	Consumables	-	Sufficient quantity.

STATE BOARD OF TECHNICAL EDUCATION & TRAINING, TAMILNADU
DIPLOMA IN ENGINEERING / TECHNOLOGY SYLLABUS
N - SCHEME

(To be implemented for the students admitted from the year 2020 - 2021 onwards)

Course Name : 1020 Diploma in Mechanical Engineering
 Subject Code : 4020470
 Semester : IV
 Subject Title : Electrical Drives and Control Practical

TEACHING AND SCHEME OF EXAMINATION

No of weeks per semester: 16 weeks

Subject	Instructions		Examination			Duration
	Hours / Week	Hours / Semester	Marks			
Internal Assessment			Board Examinations	Total		
4020460 Electrical Drives and Control Practical	4	64	25	100*	100	3 Hrs.

* Examinations will be conducted for 100 marks and it will be reduced to 75 marks for result.

OBJECTIVES:

- Identify starters for different motors.
- Study and prepare earthing
- Test the characteristics of DC and AC machines.
- Identify and select controlling elements.
- Explore the performance of ELCB, MCB.
- Design regulated power supplies.
- Identify display devices—LED, 7 segment LED, LCD.
- Identify the drive circuit for special motors. Test the speed control circuit of the special motors.

4020460 ELECTRICAL DRIVES AND CONTROL PRACTICAL

EXPERIMENTS:

Part A:

1. Verification of Ohm's Law
2. Load test on DC shunt motor
3. Load test on single phase induction motor
4. Load test on three phase squirrel cage motor
5. Testing of relays, contactors, push buttons and limit switch
6. Connection and Testing of MCB, ELCB

Part B

1. Construction and testing of Halfwave and Fullwave rectifier.
2. Construction and testing of IC voltage regulator using IC 7805.
3. Verification of truth tables for logic gates.
4. Verification of universal gates.
5. Identification and testing of display devices - LED, 7segment LED, Laser diode.
6. Testing of Stepper motor drive.
7. Testing of Servomotor drive.

BOARD EXAMINATION

Note:

- All the experiments in both sections have to be completed. Two experiments will be given for examination by selecting one from PART A and one from PART B.
- All the experiments should be given in the question paper and students are allowed to select by a lot or Question paper issued from the DOTE should be followed.
- All the students appearing for first attempt should submit record notebook for the examination.
- The external examiner should verify the availability of the facility for the batch strength before commencement of practical examination.
- The external examiner should verify the working condition of machinery's / equipment before commencement of practical examination.

DETAILED ALLOCATION OF MARKS

Part A:		45
Circuit diagram	10	
Connections & Readings	20	
Calculations & Graph	15	
Part B:		45
Circuit diagram	10	
Connections & Readings	20	
Execution	15	
Viva Voce		10
Total		100

LIST OF EQUIPMENTS (For 30 students)

Electrical Lab

1. DC ammeter 0-5A	-	1 no
2. DC ammeter 0-25A	-	1 no
3. DC voltmeter 0-30V	-	1 no
4. DC voltmeter 0-300V	-	1 no
5. Rheostat 10.8 ,8.5A	-	1 no
6. AC ammeter 0-5A	-	1 no
7. AC ammeter 0-10A	-	2 nos.
8. AC voltmeter 0-50V	-	3 nos
9. AC wattmeter 5A-10A (0-750W,0-600V)	-	3 nos
10. Loading rheostat 5A,230V	-	1 no
11. Tachometer 0-1000rpm (Analog type)	-	1 no
12. Variac 20A,250V (Auto transformer)	-	2 nos
13. Over load relay 1 to 2.5A	-	1 no
14. Air break contactors 20A,220V	-	4 nos

15. Push button 2A ,220V	-	2 nos
16. Limit switch 20A,220V	-	1 no
17. MCB 20A single pole	-	1 no
18. MCB 20A double pole	-	1 no
19. ELCB 2pole 20A,100mA	-	1 no
20. ELCB 4POLE 20A,100mA	-	1 no

Electronics Lab

1. Transformer 230 / 9-0-9V, 1A	-	4 nos.
2. Resistor 1 K Ω / $\frac{1}{2}$ W	-	3 nos.
3. Capacitor 1000 μ F/25V	-	4 nos.
4. IC 7805	-	1 no.
5. Logic Gates IC		
7400, 7408, 7432, 7404,7402, 7486-		1 each
6. Stepper Motor Drive kit	-	1no.
7. Servo Motor Drive Kit	-	1no
8. Digital Multimeter	-	1no.
9 LED, 7 Segment LED, Laser Diode	-	1 each

STATE BOARD OF TECHNICAL EDUCATION & TRAINING, TAMILNADU
DIPLOMA IN ENGINEERING / TECHNOLOGY SYLLABUS
N-SCHEME

(To be implemented for the students admitted from the year 2020 - 2021 onwards)

Course Name : 1020 Diploma in Mechanical Engineering
 Subject Code : 4020510
 Semester : V
 Subject Title : Design of Machine Elements

TEACHING AND SCHEME OF EXAMINATION

No of weeks per semester: 16 weeks

Subject	Instructions		Examination			
	Hours / Week	Hours / Semester	Marks			Duration
Internal Assessment			Board Examinations	Total		
4020510 Design of Machine Elements	6	96	25	100*	100	3 Hrs.

* Examinations will be conducted for 100 marks and it will be reduced to 75 marks for result.

Topics and Allocation of Hours

Unit No	Topics	Hours
I	Engineering Materials and Joints	18
II	Design Of Shafts, keys and Couplings	18
III	Design of Flat Belts and V-Belts	18
IV	Design of Bearings & Spur Gears	18
V	Computer Aided Design (CAD) and Geometrical Modelling	17
Test and Model Exam		7
Total		96

RATIONALE:

The main objective of Machine Design is to create new and better machine components to improve the existing one. A mechanical engineer should have thorough knowledge of design of machine elements to avoid the failure of machines or components.

OBJECTIVES:

- Design sleeve and cotter joint, knuckle joint and Welded joints
- Design shafts, keys and couplings required for power transmission.
- Compare the different types of couplings.
- Design flat and V-belt for power transmission.
- Study the various types of bearings and their applications.
- Design journal bearings.
- Design Spur gear.
- Role of CAD in design and analysis.

**4020510 DESIGN OF MACHINE ELEMENTS
DETAILED SYLLABUS**

Contents: Theory

Unit	Name of the Topics	Hours
I	<p>Engineering Materials and Joints</p> <p><u>Chapter: 1.1:</u> General Considerations in Machine Design. Engineering materials - Factors affecting selection of material – BIS designation of Ferrous materials – Preferred number - Factor of safety and allowable stress – Stresses: Tension, Compression, Shear, Bearing pressure Intensity, Crushing, bending and torsion - problem. Creep strain and Creep Curve- Fatigue, S-N curve, Endurance Limit - Stress Concentration – Causes & Remedies. Theories of Elastic Failures – Principal normal stress theory, Maximum shear stress theory & maximum distortion energy theory.</p> <p><u>Chapter: 1.2:</u></p>	<p>10</p> <p>8</p>

	Joints: Design of sleeve and cotter joint, knuckle joint and welded joint.	
II	<p>Design Of Shafts, Keys and Couplings</p> <p>Chapter: 2.1:</p> <p>Shafts: Design of shafts subjected to – twisting moment – bending moment – combined twisting and bending moments – fluctuating loads – design of shafts based on rigidity.</p> <p>Chapter: 2.2:</p> <p>Keys: Types of keys - design of sunk keys only - Effect of keyways on shaft - problems.</p> <p>Couplings: Requirements of good couplings – types - design of - rigid protected type flange couplings - marine couplings – pin type flexible coupling (Description only).</p>	9
III	<p>Design of Flat Belts and V-Belts:</p> <p>Chapter: 3.1:</p> <p>Flat Belts: Types of belts - materials for belt -- types of belt drives – Speed ratio – effect of slip - length of flat belts –Tension Ratio $T_1/T_2=e^{\mu\theta}$ – centrifugal tension - power transmitted – condition for maximum power - transmission – Initial Tension - problems - design procedure of flat belts - design of flat belt based on manufacturer’s data only – problems.</p> <p>Chapter: 3.2:</p> <p>V-belt drive - comparison with flat belt drive - designation of V-belts – length of belt - power transmitted – Design of V-belt using manufacturer’s data only – Problem.</p>	9
IV	<p>Design of Bearings & Spur Gears</p> <p>Chapter: 4.1:</p> <p>Bearings: Classifications of bearings – sliding contact and rolling contact bearings - radial and thrust bearings - roller bearing – types - Designation of ball bearings - materials used for bearings - journal bearings - heat generated - heat dissipated - cooling oil requirement – problems - design of journal bearings – Problems. (Design based on approved data books only.).</p>	10

	<p><u>Chapter: 4.2:</u></p> <p>Spur Gears: Gear drives - Types of gears - applications - materials - spur gear terminology - design of spur gear based on Lewis and Buckingham equation (design procedure only) - speed reducer – types.</p>	8
V	<p>Computer Aided Design (CAD) and Geometric Modelling</p> <p><u>Chapter: 5.1:</u></p> <p>CAD – Roles of CAD in design – Development and uses - Applications – Advantages – Product cycle – Design process: Shigley Model - Pahl and Beitz Model – Sequential Engineering – Concurrent Engineering – 2D and 3D Transformation.</p> <p><u>Chapter: 5.2:</u></p> <p>Geometric Modelling: Solid modelling – entities – advantages and disadvantages – Boolean operations - Boundary representation – Constructive Solid Geometry – Comparison – Finite Element analysis – Steps.</p>	9
		8

Reference Book:

- Machine Design, Pandya & Shah, Edn. 1995, Charotar Publishing House.
- Machine Design, T. V. Sundararamoorthy & N. Shanmugam, Revised Edition June-2003–Anuradha Publications.
- Design Data Book – by PSG College of Technology, DPV Printers.
- A text book of Machine Design, R.S. Khurmi & J.K.Gupta, Edn. 18, Euroasia Publishing House Pvt. Limited.
- Machine Design, Bandari,
- Theory and Problems of Machine Design, Holowenko, Laughlin, Schaum's outline series.
- R.Radhakrishnan, and S.Subramanian, "CAD/CAM/CIM", New Age International Pvt Limited.

STATE BOARD OF TECHNICAL EDUCATION & TRAINING, TAMILNADU
DIPLOMA IN ENGINEERING / TECHNOLOGY SYLLABUS
N - SCHEME

(To be implemented for the students admitted from the year 2020 - 2021 onwards)

Course Name : 1020 Diploma in Mechanical Engineering
 Subject Code : 4020520
 Semester : V
 Subject Title : Thermal Engineering - II

TEACHING AND SCHEME OF EXAMINATION

No of weeks per semester: 16 weeks

Subject	Instructions		Examination			
	Hours / Week	Hours / Semester	Marks			Duration
Internal Assessment			Board Examinations	Total		
4020520 Thermal Engineering - II	5	80	25	100*	100	3 Hrs.

* Examinations will be conducted for 100 marks and it will be reduced to 75 marks for result.

Topics and Allocation of Hours

Unit No	Topics	Hours
I	Formation and Properties of Steam & Thermodynamic Processes of Vapour	15
II	Steam Boilers and Performance Of Boiler	15
III	Thermal Power Plant and Steam Turbines and Condensers	15
IV	Conventional Sources of Energy and Nuclear Power Plant	13
V	Air Compressors and Gas Turbines	15
Test and Model Exam		7
Total		80

RATIONALE:

This subject is one of the core subjects. Diploma engineers have to work with various power producing and power absorbing devices. This subject will enable students to establish foundation required to operate and maintain the devices. This subject emphasizes on steam boilers and allied components that are used in industrial sectors. Thermal power plants are still contributing major share in electricity production in India.

OBJECTIVES:

- Define various types of steam.
- Explain the working of Boiler.
- Compare various types of Boilers.
- Familiarize boiler mounting and accessories.
- Describe various circuits used in the thermal power plant.
- Explain working of steam turbine and condensers.
- Compare conventional energy sources with Non-Conventional Sources of energy.
- Explain working of nuclear power plant.

4020520 THERMAL ENGINEERING - II

DETAILED SYLLABUS

Contents: Theory

Unit	Name of the Topic	Hours
I	Formation and Properties of Steam & Thermodynamic Processes of Vapour Steam - Properties – formation of steam– saturation temperature – enthalpy of water – enthalpy of evaporation – conditions of steam – wet, dry and superheated steam - dryness fraction – enthalpy of wet, dry and superheated steam - advantages of superheated steam – Property diagrams – p-v diagram - T-H	10

	<p>diagram – T-V diagram – T-S diagram - phase diagram-H-S diagram – P-H diagram – critical conditions of water – specific volume of water and steam – density of steam – external work done during evaporation – internal latent heat – internal energy of steam – entropy of water and steam – steam tables - Mollier chart – Description only.</p> <p>Determination of dryness fraction of steam – bucket calorimeter - combined separating and throttling calorimeters - problems.</p> <p>Expansion processes of steam - constant volume, constant pressure, constant temperature, hyperbolic, polytrophic, isentropic and throttling processes – problems.</p>	5
II	<p>Steam Boilers And Performance Of Boilers</p> <p>Introduction -Classification of boilers – comparison of fire tube and water tube boilers– high pressure boilers – advantages of high pressure boilers - BHEL high pressure boilers – boiler mountings and function- construction and working – boiler accessories and function - construction and working – comparison of mountings and accessories – feed water treatment – internal and external treatments - starting boiler from cold condition – safety precautions in boiler operation – clauses of Indian boiler act.</p> <p>Evaporation rate - actual, equivalent and factor of evaporation – boiler efficiency – factors influencing boiler efficiency - boiler power - problems – boiler plant - efficiency of economizer and super heater - problems – boiler trial – heat losses in a boiler-heat balance sheet – problems.</p>	10 5

<p>III</p>	<p>Thermal Power Plant And Steam Turbines and condensers</p> <p>Selection of site for thermal power plant -Layout of thermal power plant – fuel and ash circuit – water and steam circuit – air and flue gas circuit – cooling water circuit – merits and demerits of thermal power plant — air pollution by thermal power plants – pollutants, effects and control – cyclone separator – wet scrubber – electrostatic precipitator – control of No₂ and SO₂.fluidised bed combustion- thermal and noise pollution.</p> <p>Basic steam power cycles – Carnot, Rankine and modified Rankine cycles. Classification of steam turbine-Impulse and reaction turbines- Difference - necessity of compounding – Methods of compounding – special turbines.</p> <p>Steam condensers – elements of condensing plant – classification of condensers – jet condenser – surface condensers – Comparison of jet and surface condensers – sources of air in condenser – condenser vacuum – vacuum efficiency – condenser efficiency - mass of cooling water required – mass of air present – number of tubes – simple problems.</p>	<p>5</p> <p>5</p> <p>5</p>
<p>IV</p>	<p>Conventional Sources Of Energy And Nuclear Power Plant</p> <p>Conventional sources of energy – layout of hydel and diesel power plants – merits and demerits.</p> <p>Nuclear fuels –fissile and fertile fuels – Nuclear fission and fusion – chain reaction – radio activity – layout of nuclear power plant – merits and demerits – Nuclear reactors -Components–Reactor Core -moderators – control rods – coolant – reflectors – biological shield-Reactor Vessels-Classification of Reactor- pressurized water reactor – boiling water reactor – Candu type reactor – fast breeder reactor — effect of nuclear radiation – Fuel Cycle –Site selection – Safety-Floating Nuclear Power Plants-Uranium Enrichment – Methods-disposal of nuclear wastes- comparison of nuclear power plants with thermal power plants- Nuclear Power Plant in India.</p>	<p>3</p> <p>12</p>

V	Air Compressors And Gas Turbines	
	<p>Air Compressors-uses of compressed air – classifications of Air compressor – reciprocating compressor - single stage reciprocating compressor – compression processes – power required to drive the compressor (Neglecting clearance Volume) – clearance volume and its effects – volumetric efficiency –power required to drive the compressor with clearance volume – problems – multi stage compression – merits and demerits - work input – ratio of cylinder diameters for minimum work input.</p> <p>Rotary compressors – Roots blower - vane blowers – centrifugal and axial flow air compressors.</p>	6
	<p>Gas turbines – uses - classifications – merits and demerits of gas turbines -constant pressure combustion gas turbine – gas turbine with – intercooler –reheater - regenerator -effects – closed cycle gas turbines - merits and demerits of open and closed cycle gas turbines</p>	5
	<p>Jet propulsion -turbojet engines– merits and demerits – turbo propeller engines – merits and demerits – ramjet – merits and demerits – Rocket engines – solid propellant rocket -applications of rockets.</p>	4

Reference Books:

1. Thermal Engg, R.K . Rajput , ,8th Edition, Laxmi publications Pvt Ltd , New Delhi.
2. Applied Thermodynamics, P.K. Nag, ,2nd Edition, TATA Mcgraw – Hill Publishing Company, New Delhi .
3. Thermal Engineering, R.S. Khurmi and J.K. Gupta, 18th Edition,S.Chand & Co,NewDelhi
4. Thermal Engineering ,P.L Ballaney , 24th Edition ,Khanna Publishers,New Delhi.
5. Thermal Engineering ,B.K. Sarkar , 3rd Edition , Dhanpat Rai & Sons New Delhi .
6. Applied Thermodynamics, Domkundwar and C.PKothandaraman, 2ndEdition Khanna publishers, New Delhi.

Blank page

STATE BOARD OF TECHNICAL EDUCATION & TRAINING, TAMILNADU
DIPLOMA IN ENGINEERING / TECHNOLOGY SYLLABUS
N - SCHEME

(To be implemented for the students admitted from the year 2020 - 2021 onwards)

Course Name : 1020 Diploma in Mechanical Engineering
 Subject Code : 4020531
 Semester : V
 Subject Title : Computer Integrated Manufacturing

TEACHING AND SCHEME OF EXAMINATION

No of weeks per semester: 16 weeks

Subject	Instructions		Examination			
	Hours / Week	Hours / Semester	Marks			Duration
Internal Assessment			Board Examinations	Total		
4020531 Computer Integrated Manufacturing	5	80	25	100*	100	3 Hrs.

* Examinations will be conducted for 100 marks and it will be reduced to 75 marks for result.

Topics and Allocation of Hours

Unit No	Topics	Hours
I	Computer Aided Design	15
II	Computer Aided Manufacturing	14
III	CNC programming	16
IV	FMS, AGV, AS/RS, Robotics	14
V	Advanced concepts of CIM	14
Test and Model Exam		7
Total		80

RATIONALE:

As per the latest requirements in the Industries this enables to learn the various concepts of Computer Aided Design and Manufacturing. They are able to operate CNC machines and write part program. They are able to understand the advanced concepts adopted in automated industries.

OBJECTIVES:

- Acquire knowledge in the field of Computer aided Design
- Explain the various concepts of Computer Aided manufacturing
- Write part program for manufacturing components in CNC machines
- Explain the concepts of automatic material handling and storage systems and robotics
- Explain the advanced concepts of CIM

DETAILED SYLLABUS

Contents: Theory

Unit	Name of the Topics	Hours
I	Computer Aided Design	
	Computer Aided Design: Introduction – definition – Shigley’s design process – CAD activities – benefits of CAD - CAD software packages – point plotting, drawing of lines, Bresenham’s circle algorithm, Transformations: 2D & 3D transformations – translation, scaling, rotation and concatenation.	6
	Geometric modelling: Techniques - Wire frame modelling – applications – advantages and disadvantages. Surface modelling – types of surfaces – applications – advantages and disadvantages – Solid modelling – entities – advantages and disadvantages – Boolean operations - Boundary representation – Constructive Solid Geometry – Comparison.	6
	Graphics standard: Definition – Need - GKS –IGES – DXF. Finite Element Analysis: Introduction – Development - Basic steps – Advantages.	3
II	Computer Aided Manufacturing	
	CAM – Definition - functions of CAM – benefits of CAM. Introduction of CIM – concept of CIM - evolution of CIM – CIM wheel – Benefits – integrated CAD/CAM.	3

	<p>Group technology: Part families - Parts classification and coding - coding structure – Opitz system, MICLASS system and CODE System. Process Planning: Introduction – Computer Assisted Process Planning (CAPP) – Types of CAPP - Variant type, Generative type – advantages of CAPP. Production Planning and Control (PPC): Definition – objectives - Computer Integrated Production management system – Master Production Schedule (MPS) – Capacity Planning – Materials Requirement Planning (MRP) – Manufacturing Resources Planning (MRP-II) – Shop Floor Control system (SFC) - Just In Time manufacturing philosophy (JIT) - Introduction to Enterprise Resources Planning (ERP).</p>	<p>6</p> <p>5</p>
III	<p>CNC Programming</p> <p>NC in CAM, tooling for CNC – ISO designation for tooling – CNC operating system. Programming for CNC machining – part program - Manual part programming - coordinate system – Datum points: machine zero, work zero, tool zero - reference points - NC dimensioning – G codes and M codes – linear interpolation and circular interpolation - CNC program procedure - sub-program – canned cycles - stock removal – thread cutting – mirroring – drilling cycle – pocketing. Rapid prototyping: Classification – subtractive – additive – advantages and applications – materials – Virtual machining.</p>	16
IV	<p>FMS, AGV, AS/RS, Robotics</p> <p>FMS: Introduction – FMS components – FMS layouts – Types of FMS: Flexible Manufacturing Cell (FMC) – Flexible Turning Cell (FTC) – Flexible Transfer Line (FTL) – Flexible Machining System (FMS) – benefits of FMS - introduction to intelligent manufacturing system.</p> <p>Material handling in CIM environment: Types – AGV: Introduction – AGV - working principle – types – benefits. AS/RS – working principle –types – benefits.</p> <p>Robotics: Definition – robot configurations – basic robot motion – robot programming method – robotic sensors – end effectors – mechanical grippers – vacuum grippers – robot programming concepts - Industrial applications of Robot: Characteristics - material transfer and loading – welding - spray coating - assembly and inspection.</p>	<p>5</p> <p>3</p> <p>6</p>

V	<p>Advanced Concepts Of CIM</p> <p>Concurrent Engineering: Definition – Sequential Vs Concurrent engineering – need of CE – benefits of CE. Quality Function Deployment (QFD): Definition – House of Quality (HOQ) – advantages – disadvantages. Steps in Failure Modes and Effects Analysis (FMEA) – Value Engineering (VE) – types of values – identification of poor value areas – techniques – benefits. Guide lines of Design for Manufacture and Assembly (DFMA). Product Development Cycle: Product Life Cycle - New product development processes. Augmented Reality (AR) – Introduction - concept – Applications.</p>	14
----------	---	-----------

REFERENCES BOOKS:

1. R.Radhakrishnan, and S.Subramanian, “CAD/CAM/CIM”, New Age International Pvt. Ltd.
2. Mikell P.Groover, and Emory Zimmers, “CAD/CAM”, Jr.Prentice Hall of India Pvt., Ltd.
3. Dr.P.N.Rao, “CAD/CAM Principles and Applications,”, Tata Mc Graw Hill Publishing Company Ltd.
4. Ibrahim Zeid, “Mastering CAD/CAM”, Tata McGraw-Hill Publishing Company Ltd., New Delhi.
5. Mikell P. Groover, “Automation, Production Systems, and Computer-Integrated Manufacturing”, Pearson Education Asia.
6. Yoram Koren, “Computer control of manufacturing systems,”, McGraw Hill Book.
7. Chris McMahan and Jimmie Browne, “CAD/CAM – Principle Practice and Manufacturing Management”, Addison Wesley England, Second Edition,2000.
8. Dr.Sadhu Singh, “Computer Aided Design and Manufacturing,”, Khanna Publishers, NewDelhi, Second Edition,2000.
9. S.Kant Vajpayee, “Principles of Computer Integrated Manufacturing,”, Prentice Hall of India, 1999.
10. David Bed worth, “Computer Integrated Design and Manufacturing,”, TMH, 1998.

STATE BOARD OF TECHNICAL EDUCATION & TRAINING, TAMILNADU
DIPLOMA IN ENGINEERING / TECHNOLOGY SYLLABUS
N - SCHEME

(To be implemented for the students admitted from the year 2020 - 2021 onwards)

Course Name : 1020 Diploma in Mechanical Engineering
 Subject Code : 4020532
 Semester : V
 Subject Title : Green Energy and Energy Conservation

TEACHING AND SCHEME OF EXAMINATION

No of weeks per semester: 16 weeks

Subject	Instructions		Examination			
	Hours / Week	Hours / Semester	Marks			Duration
Internal Assessment			Board Examinations	Total		
4020532 Green Energy and Energy Conservation	5	80	25	100*	100	3 Hrs.

* Examinations will be conducted for 100 marks and it will be reduced to 75 marks for result.

Topics and Allocation of Hours

Unit No	Topics	Hours
I	Fundamentals of Energy, Geothermal energy, Wind energy	15
II	Bio mass energy, Solar Energy	15
III	Photovoltaic (PV)	15
IV	PV Technologies, Applications	14
V	Energy conservation	14
Test and Model Exam		7
Total		80

RATIONALE:

There is an ever increasing demand for energy in spite of the rising prices of oil & other fossil fuel / depletion of fossil fuels. Energy demand, in particular electricity production has resulted in creation of fossil fuel based power plants that let out substantial greenhouse gas / carbon emission into the atmosphere causing climate change and global warming. We have various forms of renewable energy sources viz., Wind, Solar, Biomass, Biogas, etc. Municipal and Industrial wastes could also be useful sources of energy while ensuring safe disposal. This subject is introduced to learn about the major renewable energy sources and more focus on the PV module solar energy. The government act and guidelines are discussed for the benefit of the Diploma Engineers.

OBJECTIVES:

1. Study about the fundamentals of Energy.
2. Study of construction and principle of Wind energy, Solar energy, Geo thermal and Bio energy.
3. Understand the solar energy.
4. Understand the PV design and its components.
5. Study the energy conservation process.
6. Understand the Government Policies and Acts.
7. Study the TEDA projects in Tamil Nadu.

4020532 GREEN ENERGY AND ENERGY CONSERVATION

DETAILED SYLLABUS

Contents: Theory

UNIT	Name of the Topics	Hrs.
I	Fundamentals of Energy, Geothermal energy, Wind energy Energy: Introduction – Energy need and trends - Forms of Energy – First Law of Thermodynamics - Second Law of Thermodynamics – energy requirement and supply – Fossil fuels and climate changes – need of renewable energy sources – Current renewable energy uses – Renewable energy policies in India.	5
	Geothermal energy: Introduction – Essential characteristic –	4

	<p>Sources – Power Plants – Single flash power plant – double flash power plant – Flow diagram and principle only.</p> <p>Wind energy: Introduction – energy conversion – site selection considerations – Components of wind energy conversion system – Classification. Wind mill: Horizontal axis machines - Vertical axis machines – working principle, advantages and disadvantages. Schemes for electric generation.</p>	6
II	<p>Bio mass energy, Solar Energy</p> <p>Bio mass energy: Introduction – conversion technologies: Wet processes – dry processes. Bio gas generation – factors affecting the bio gas generation – classification of bio gas plants – Bio gas plant – construction - advantages and disadvantages. Materials used for bio gas generation – factors to be considered for the selection of site.</p> <p>Solar Energy: Introduction – Sun’s energy: advantages – conversion challenges– The Sun-Earth movement - Solar radiation - Different angles - optimal angle for fixed collector, in summer and winter. Sun tracking - measuring instruments of solar radiation – methods to estimate solar radiation.</p>	7 8
III	<p>Photovoltaic (PV)</p> <p>Photovoltaic (PV): Semiconductors as solar cell – types of unit cells - electronic arrangement of silicon atom – intrinsic semiconductor – extrinsic semiconductor – Description only. P-N junction diode - forward bias - reverse bias. Solar cell - characteristics - description of short circuit current, open circuit voltage, fill factor and efficiency - losses in solar cells.</p> <p>Growth of solar PV and silicon (Si) requirement – production of metallurgical grade (MGS) – production of electronic grade (EGS) – Production of Si wafers: ingot making - monocrystalline - multicrystalline – wafer dicing. Si sheets. Solar grade silicon (SoG) – refining processes – Si usage in Solar PV. Process flow of commercial Si cell technology – Description of saw damage removal and surface texturing, diffusion process, thin-film layers for</p>	6 9

Reference Books

1. Non Conventional Energy Sources, G.D.Rai, Khanna Publishers.
2. Non Conventional Energy Sources and Utilisation, R.K.Rajput, S.Chand & Company Ltd.
3. Renewable Energy, Stephen Peake, Oxford press
4. Non Conventional Energy Resources, B.H.Khan, Tata Mc Graw Hill.
5. Industrial energyconservation- D. A. Ray- Pergaman Press
6. Energy resource management, Kirpal Singh Jogi, Sarup and sons.
7. Solar Photovoltaics, Chetan Singh Solanki, PHI Learning Pvt. Ltd.
8. Renewable Energy Engineering and Technology, V V N Kishore, TERI.
9. Principles of Solar Engineering, D.Yogi Goswami, Frank Kreith, Jan F.Kreider, Taylor & Francis.
10. Energy conservation act 2001, Government of India.
11. Energy Conservation Guidelines for Industries, Bureau of energy Efficiency, Ministry of Power, Government of India.
12. Tamil Nadu Solar policy 2019
- 13) <https://teda.in/achievements/solar-energy-4/>
- 14) <https://teda.in/achievements/bio-energy-2/>
- 15) <https://teda.in/achievements/wind-energy-2/>

Blank Page

STATE BOARD OF TECHNICAL EDUCATION & TRAINING, TAMILNADU
DIPLOMA IN ENGINEERING / TECHNOLOGY SYLLABUS
N - SCHEME

(To be implemented for the students admitted from the year 2020 - 2021 onwards)

Course Name : 1020 Diploma in Mechanical Engineering
 Subject Code : 4020533
 Semester : V
 Subject Title : Mechatronics

TEACHING AND SCHEME OF EXAMINATION

No of weeks per semester: 16 weeks

Subject	Instructions		Examination			
	Hours / Week	Hours / Semester	Marks			Duration
Internal Assessment			Board Examinations	Total		
4020533 Mechatronics	5	80	25	100*	100	3 Hrs.

* Examinations will be conducted for 100 marks and it will be reduced to 75 marks for result.

Topics and Allocation of Hours

Unit No	Topics	Hours
I	Introduction, Sensors & Transducers	15
II	Actuation systems	14
III	Basic system models, Input / Output systems	14
IV	Programmable Logic Controller	14
V	Design examples & advanced applications In Mechatronics	16
Test and Model Exam		7
Total		80

RATIONALE:

As per the latest requirements in the automation industries this enables to learn the various concepts of automation components. They are able to write program, and operate PLCs. They are able to select the electronic components for various industry applications.

OBJECTIVES:

- Explain the working of sensors and transducers
- Acquire knowledge about actuation systems
- Explain the system models and I/O systems
- Write program and operate PLCs
- Explain the applications of mechatronics

4020533 MECHATRONICS**DETAILED SYLLABUS**

Contents: Theory

Unit	Name of the Topics	Hours
I	Introduction, Sensors & Transducers Introduction – Systems – Measurement Systems – Control Systems – Microprocessor Based Controllers. Examples – Mechatronics approach. Measurement System terminology – Displacement, Position & Proximity Sensors – Velocity and Motion Sensors – Force Sensors – Fluid Pressure Sensors – Flow Sensors – Liquid Level Sensors – Temperature Sensors – Light Sensors – Selection of Sensors – Calibration of sensors.	15
II	Actuation Systems Mechanical Actuation Systems – Types of motion – Freedom and constraints – Loading – Gear Trains – Pawl & Ratchet – Belt & Chain drive – Bearing – Selection – Ball & Roller bearings – Mechanical aspects of motor selection. Electrical Actuation Systems – Switches & Relays – Solenoids – D.C Motors – A.C. Motors – Stepper Motors – Specification and control of	7 7

	stepper motors – Servomotors: D.C Servomotor and A.C Servomotor. Pneumatic & Hydraulic Systems – Power supplies – DCV – PCV – Cylinders – Rotary actuators.	
III	Basic System Models, Input/Output Systems Mathematical Model – Introduction to mathematical model – Mechanical System building blocks – Electrical System building blocks – Fluid System building blocks – Thermal System building blocks. System Model – Engineering Systems – Rotational – Translational Systems – Electro-Mechanical System – Hydro- Mechanical System. Interfacing – Input/Output ports – Interface requirements: Buffers, Handshaking, Polling and interrupts, Serial interfacing – Introduction to PIA – Serial communications interface – Example of interfacing of a seven-segment display with a decoder.	14
IV	Programmable Logic Controller Definition – Basic block diagram and structure of PLC – Input/Output processing – PLC Programming: Ladder diagram, logic functions, latching and sequencing – PLC mnemonics – Timers, internal relays and counters – Shift registers – Master and jump controls – Data handling – Analog input/output – Selection of PLC – sample ladder programs.	14
V	Design Examples & Advanced Applications In Mechatronics Design process stages – Traditional Vs Mechatronics designs – Possible design solutions: Timed switch, Wind- screen wiper motion, Bath room scale – Case studies of mechatronics systems: A pick-and-place robot, Car park barrier, Car engine management system, Automatic Camera and Automatic Washing Machine. Sensors for condition monitoring systems of production systems – Examples of monitoring methods: Vibration monitoring, Temperature monitoring, Wear behavior monitoring – Mechatronics control in automated manufacturing: Monitoring of manufacturing processes, On-line quality monitoring, Model-based systems, Hardware-in-the-loop simulation, Supervisory control in manufacturing inspection, Integration of heterogeneous systems.	16

REFERENCES BOOKS:

1. W.Bolton, "Mechatronics", 2nd Edition 2001, Pearson Education, New Delhi.
2. R.K.Rajput, A Text Book of Mechatronics, 1st Edition 2007, S.Chand & Co. Ltd., New Delhi.
3. HMT, "Mechatronics", 1st Edition 1998, Tata McGraw Hill, New Delhi.
4. Devdas Shetty & Kolk, "Mechatronics System Design", 1st Reprint, 2001, PWS Publishing Co., Boston.
5. James H.Harter, "Electromechanics", 1st Edition 2003, Prentice-Hall of India, New Delhi.
6. M.D.Singh & J.G.Joshi, "Mechatronics", 1st Edition 2006, Prentice-Hall of India, New Delhi.

STATE BOARD OF TECHNICAL EDUCATION & TRAINING, TAMILNADU
DIPLOMA IN ENGINEERING / TECHNOLOGY SYLLABUS
N – SCHEME

(To be implemented for the students admitted from the year 2020 – 2021 onwards)

Course Name : 1020 Diploma in Mechanical Engineering
 Subject Code : 4020540
 Semester : V
 Subject Title : Process Automation Practical

TEACHING AND SCHEME OF EXAMINATION

No of weeks per semester: 16 weeks

Subject	Instructions		Examination			
	Hours / Week	Hours / Semester	Marks			Duration
Internal Assessment			Board Examinations	Total		
4020540 Process Automation Practical	4	64	25	100*	100	3 Hrs.

* Examinations will be conducted for 100 marks and it will be reduced to 75 marks for result.

OBJECTIVES:

- Design and operate pneumatic circuits.
- Design and operate fluid power circuits
- Use PLC system and its elements for process control
- Familiarize the working of function blocks in PLC
- Use ON-Delay timer to control a motor
- Use OFF-Delay timer to control a motor
- Use counter function block (Up counter and Down counter)
- Control the automatic operation of pneumatic cylinder using PLC
- Record of work to be prepared.

Exercises

PART A

Pneumatics Lab.

1. Direct operation of single and double acting cylinder.
2. Operation of double acting cylinder with quick exhaust valve.
3. Speed control of double acting cylinder using metering-in and metering-out circuits.
4. Automatic operation of double acting cylinder in single cycle - using limit switch.

Hydraulics Lab.

5. Direct operation of double acting cylinder.
6. Direct operation of hydraulic motor.
7. Speed control of double acting cylinder metering-in and metering-out control.

PART B

PLC Lab.

1. Direct operation of a motor using latching circuit.
2. Operation of a motor using 'AND' logic control.
3. Operation of a motor using 'OR' control.
4. On-Delay control of a motor and Off –Delay control of a motor.
5. Automatic operation of a Double acting cylinder-single cycle - forward, time delay, return.
6. Automatic operation of Double acting cylinder-Multi cycle.
7. Sequential operation of double acting cylinder and a motor.

BOARD EXAMINATION

Note:

- All the experiments in both sections should be completed. Two experiments will be given for examination by selecting one exercise from PART A and one exercise from PART B.
- All the experiments should be given in the question paper and students are allowed to select by a lot or Question paper issued from the DOTE should be followed.
- All regular students appearing for first attempt should submit record notebook for the examination.
- The external examiner should verify the availability of the facility for the batch strength before commencement of practical examination.
- The external examiner should verify the working condition of machinery's / equipment before commencement of practical examination.

Detailed Allocation of Marks

Part A:		45
Procedure / Circuit diagram	10	
Identification of Components	15	
Connection and execution	20	
Part B:		45
Procedure / Circuit diagram	10	
Ladder diagram / Programming	25	
Execution	10	
Viva Voce		10
Total		100

LIST OF EQUIPMENTS (For 30 Students)

1. Pneumatic Trainer Kit – 3 Nos
(All Cylinders, Control Valves, Limit switches and other accessories)
2. Hydraulics Trainer Kit – 2 No.
(All Cylinders, Control Valves, Limit switches and other accessories)
3. PLC kit – 3 Nos.
4. Computer with software – 10 Nos.

Blank Page

STATE BOARD OF TECHNICAL EDUCATION & TRAINING, TAMILNADU
DIPLOMA IN ENGINEERING / TECHNOLOGY SYLLABUS
N - SCHEME

(To be implemented for the students admitted from the year 2020 - 2021 onwards)

Course Name : 1020 Diploma in Mechanical Engineering
 Subject Code : 4020550
 Semester : V
 Subject Title : Thermal Engineering Practical

TEACHING AND SCHEME OF EXAMINATION

No of weeks per semester: 16 weeks

Subject	Instructions		Examination			
	Hours / Week	Hours / Semester	Marks			Duration
Internal Assessment			Board Examinations	Total		
4020550 Thermal Engineering Practical	4	64	25	100*	100	3 Hrs.

* Examinations will be conducted for 100 marks and it will be reduced to 75 marks for result.

OBJECTIVES:

- Determine the flash and fire point and viscosity of oil.
- Draw the valve timing diagram of petrol and diesel engines.
- Draw the port timing diagram of petrol and diesel engines.
- Conduct performance test on petrol and diesel engines.
- Prepare heat balance sheet for an IC engine.
- Conduct of C.O.P of Refrigerators.
- Determine the volumetric efficiency of the Air Compressor.

Experiments:

PART - A

1. Determine flash and fire point of the given oil using open cup and closed cup apparatus.
2. Determine the absolute viscosity of the given lubricating oil using Redwood viscometer.
3. Determine the absolute viscosity of the given lubricating oil using Say bolt viscometer.
4. Port timing diagram of two stroke petrol Engine
5. Valve time diagram for four stroke petrol Engine.
6. Valve time diagram for four stroke diesel engines.

PART - B

1. Load test (Performance test) on Four Stroke Petrol Engine.
2. Load test (Performance test) on Four Stroke diesel Engine.
3. Morse test on Multi-cylinder petrol engine.
4. Heat balance test on Four Stroke Diesel / Petrol Engine.
5. Volumetric efficiency of Air Compressor.
6. Determination of COP of Refrigeration System.

BOARD EXAMINATION

Note:

- All the experiments in both sections should be completed. Two experiments will be given for examination by selecting one exercise from PART A and one exercise from PART B.
- All the experiments should be given in the question paper and students are allowed to select by a lot or Question paper issued from the DOTE should be followed.
- All regular students appearing for first attempt should submit record notebook for the examination.
- The external examiner should verify the availability of the facility for the batch strength before commencement of practical examination.
- The external examiner should verify the working condition of machinery's / equipment before commencement of practical examination.

Detailed Allocation of Marks

Part A:		35
Observation and Tabular Column	5	
Calculations	20	
Result / Graph	10	
Part B:		55
Observation and Tabular Column	10	
Formulae, Calculations	30	
Result / Graph	15	
Viva Voce		10
Total		100

LIST OF EQUIPMENTS (For 30 students)

- | | |
|--|---------------------|
| 1. Open cup apparatus | - 2 Nos. |
| 2. Close cup apparatus | - 2 Nos. |
| 3. Redwood viscometer | - 2 Nos. |
| 4. Say bolt viscometer | - 2 Nos. |
| 5. Four stroke petrol engine Model | - 2 Nos. |
| 6. Four stroke diesel engine Model | - 2 Nos. |
| 7. Two stroke petrol engine Model | - 2 Nos. |
| 8. Four stroke Petrol Engine Test rig | - 1 No. |
| 9. Four stroke Diesel engine Test rig | - 1 No. |
| 10. Multi -cylinder petrol engine test rig | - 1 No. |
| 11. Air compressor test rig | - 1 No. |
| 12. Refrigeration Test rig | - 1 No. |
| 13. Measuring instruments | - Required quantity |
| 14. Consumables | - Required quantity |

STATE BOARD OF TECHNICAL EDUCATION & TRAINING, TAMILNADU
DIPLOMA IN ENGINEERING / TECHNOLOGY SYLLABUS
N – SCHEME

(To be implemented for the students admitted from the year 2020 – 2021 onwards)

Course Name : 1020 Diploma in Mechanical Engineering

Subject Code : 4020561

Semester : V

Subject Title : Computer Integrated Manufacturing Practical

TEACHING AND SCHEME OF EXAMINATION

No of weeks per semester: 16 weeks

Subject	Instructions		Examination			
	Hours / Week	Hours / Semester	Marks			Duration
Internal Assessment			Board Examinations	Total		
4020561 Computer Integrated Manufacturing Practical	4	64	25	100*	100	3 Hrs.

* Examinations will be conducted for 100 marks and it will be reduced to 75 marks for result.

RATIONALE:

As per the latest requirements in the Industries this enables to learn the various concepts of Computer Integrated Manufacturing. They are able to write part program and able operate CNC lathe and Milling machines. They are able to understand the advanced concepts adopted in CIM.

OBJECTIVES:

- Acquire knowledge in the field of Computer Integrated Manufacturing
- Create 3D Solid models of machine components using modelling software
- Execute and perform machining operations in CNC Lathe and CNC Milling machines.

DETAILED SYLLABUS

Contents: Practical

PART A: SOLID MODELLING

Introduction to Part modelling - Datum Plane – constraint – sketch – dimensioning – extrude – revolve – sweep – blend – protrusion – extrusion – rib – shell – hole – round – chamfer – copy – mirror – assembly – align – orient – drawing and detailing –creating assembly views

Exercise No. 1. Geneva Wheel

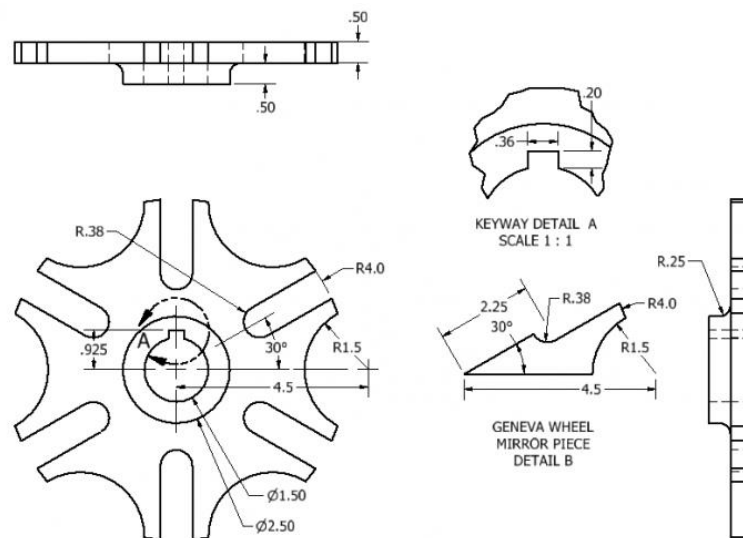

Exercise No. 2. Bearing Block

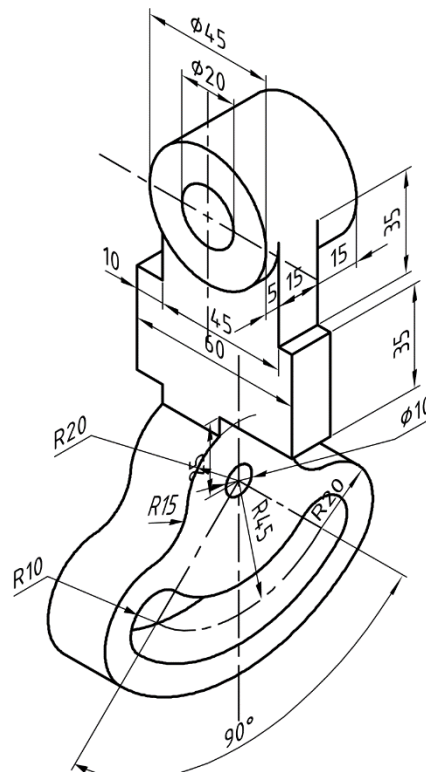

Exercise No. 3. Bushed bearing

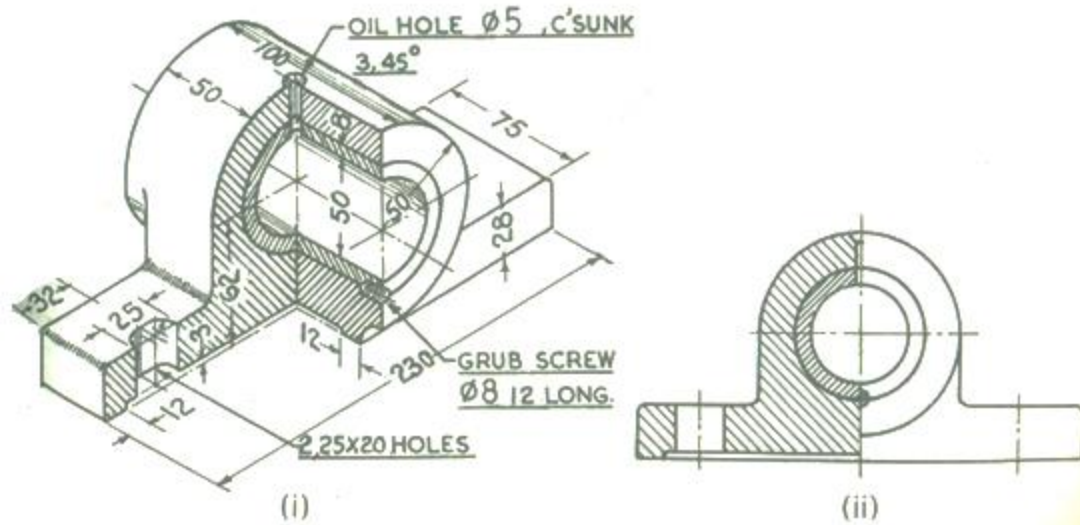

Exercise No. 4. Gib and Cotter joint

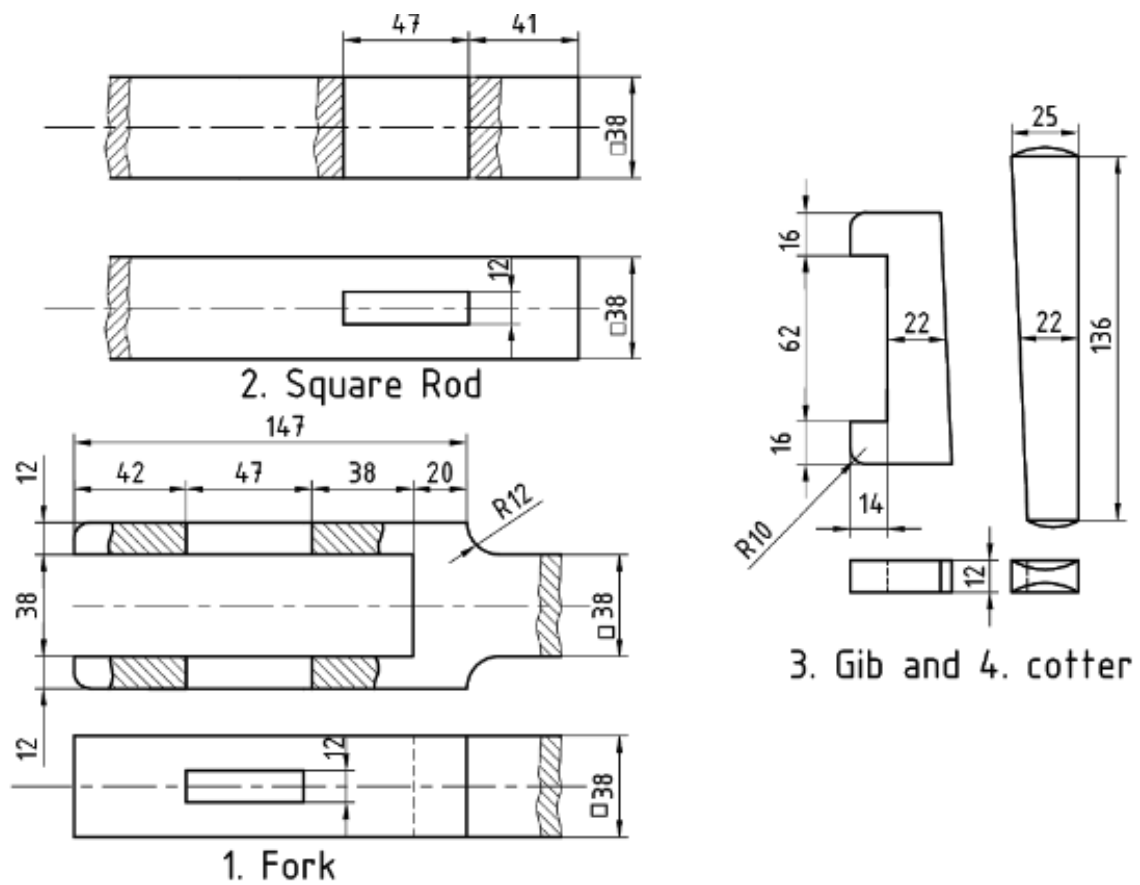

Exercise No. 5. Screw Jack

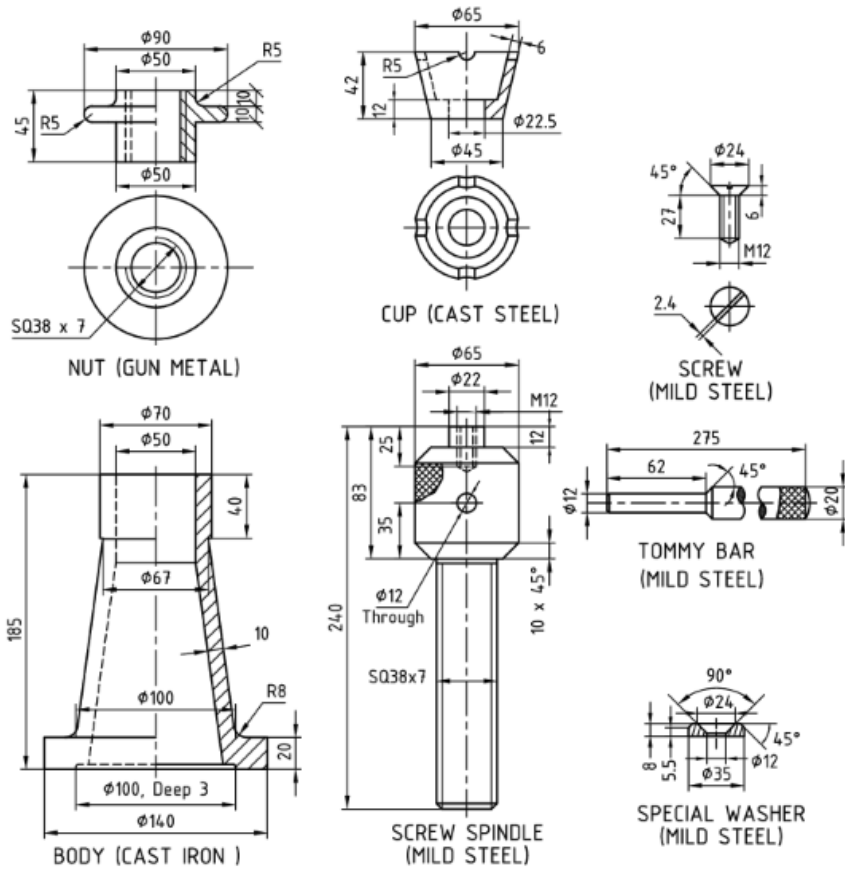

Exercise No. 6. Universal Coupling

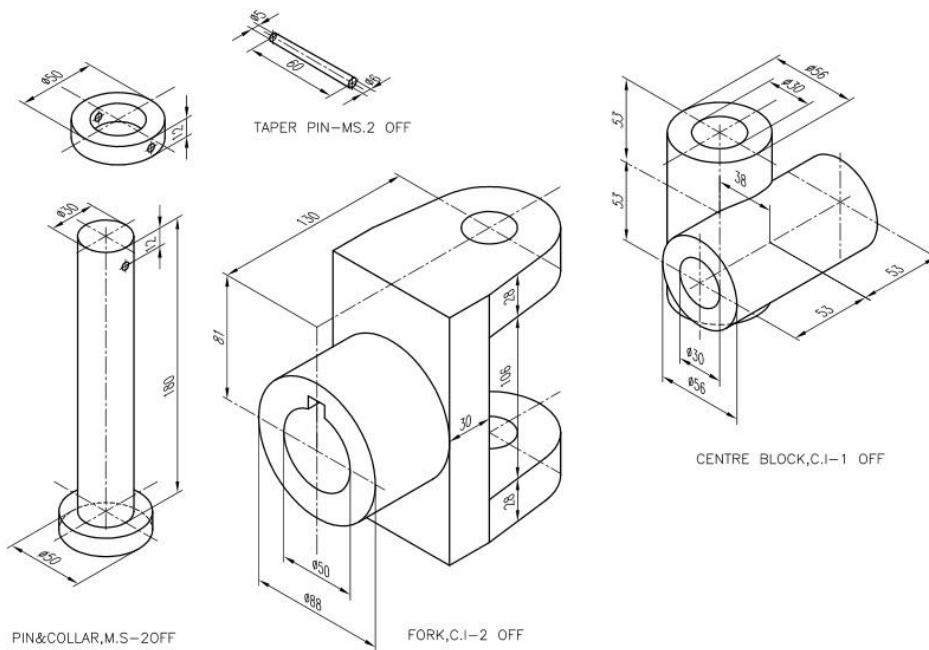

Note: Print the orthographic view and sectional view from the above assembled 3D drawing.

PART B: CNC Programming and Machining

Introduction: 1. Study of CNC lathe, milling. 2. Study of international standard codes: G-Codes and M-Codes 3. Format – Dimensioning methods. 4. Program writing – Turning simulator – Milling simulator, IS practice – commands menus. 5. Editing the program in the CNC machines. 6. Set the machine and execute the program in the CNC machines.

Note: Create and edit the part program in the simulation software for verification of the part program. Enter / transfer the program to make the component in the CNC machine.

CNC Turning Machine Material: M.S / Aluminium / Acrylic fibre / Plastic

1. Using Linear and Circular interpolation - Create a part program and produce component in the Machine.

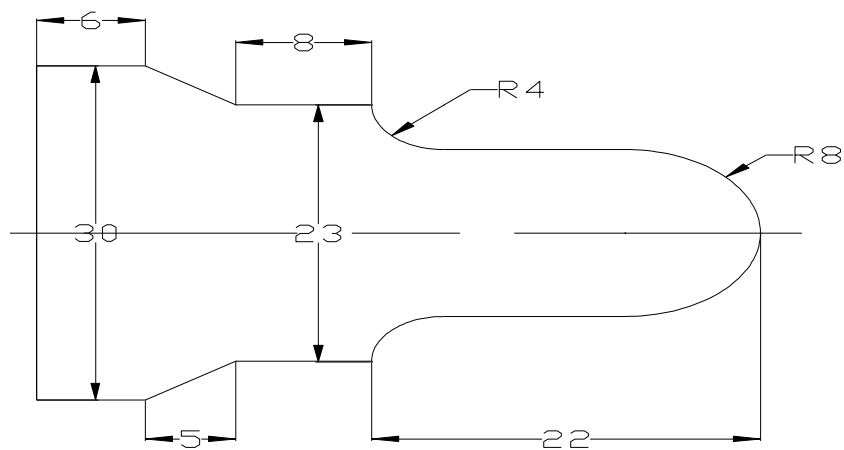

2. Using Stock removal cycle – Create a part program for multiple turning operations and produce component in the Machine.

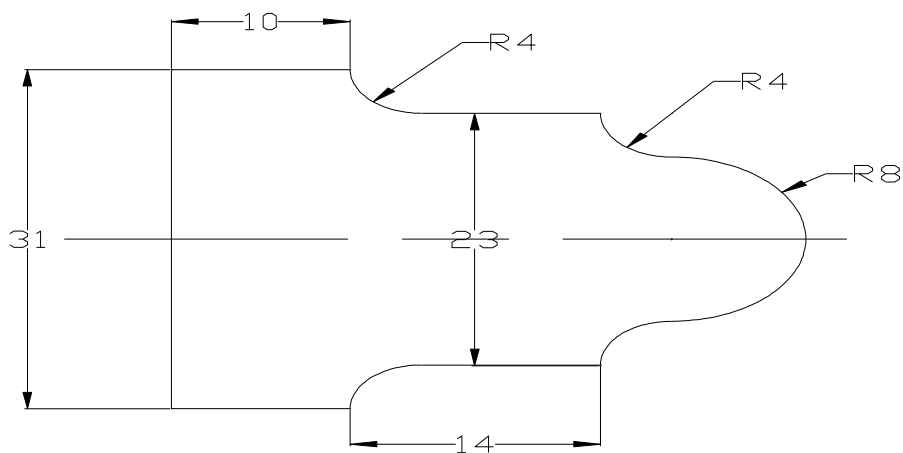

3. Using canned cycle - Create a part program for thread cutting, grooving and

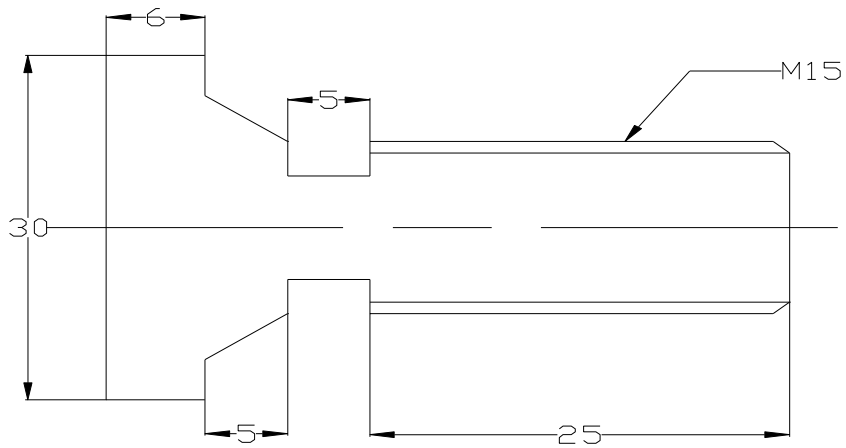

produce component in the Machine.

CNC Milling Machine

Material: M.S / Aluminum / acrylic fibre / plastic

4. Using Linear interpolation and Circular interpolation – Create a part program for grooving and produce component in the Machine.

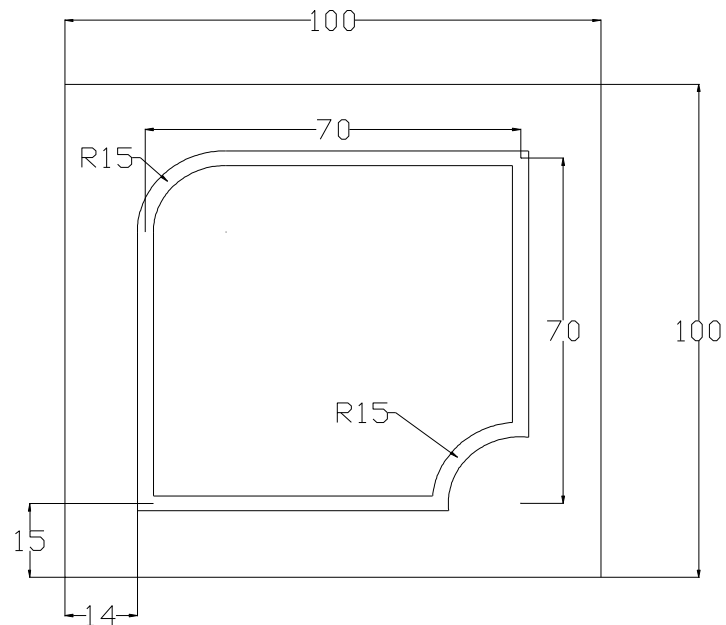

5. Using canned cycle - Create a part program for drilling, tapping, counter sinking and produce component in the Machine.

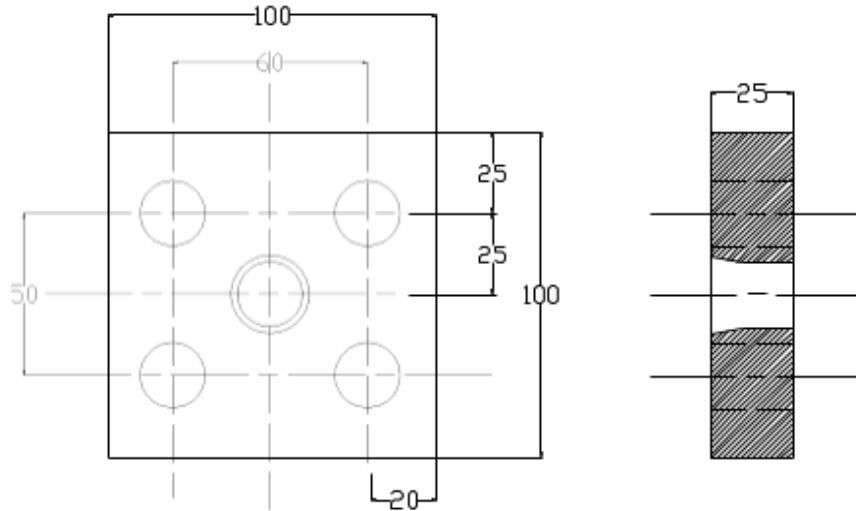

6. Using subprogram - Create a part program and produce component in the Machine.

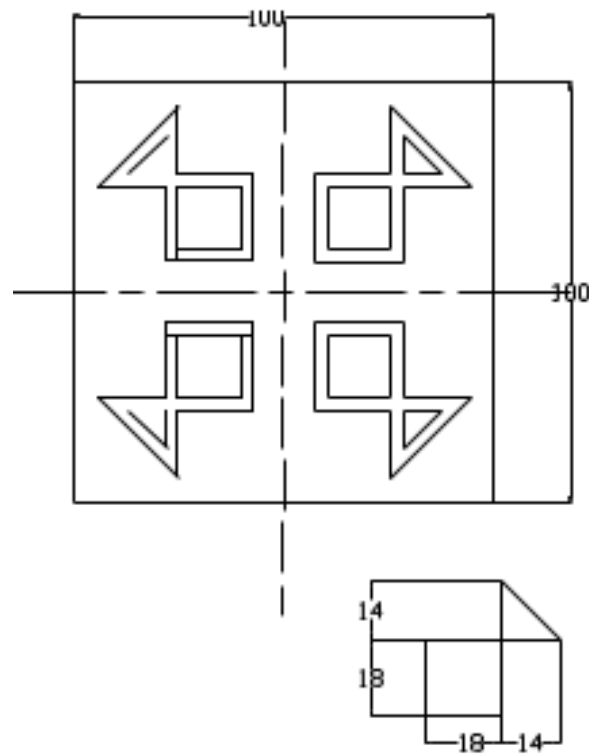

BOARD EXAMINATION

Note:

- All the exercises in both sections should be completed. Two exercises will be given for examination by selecting one exercise from PART A and one exercise from PART B.
- All the exercises should be given in the question paper and students are allowed to select by a lot or question paper issued from the DOTE should be followed.
- All regular students appearing for first attempt should submit record notebook for the examination.
- The external examiner should verify the availability of the facility for the batch strength before commencement of practical examination.
- The external examiner should verify the working condition of machinery's / equipment before commencement of practical examination.

Note: Part A: The given component drawing should be created and solid modelling after assembly should be printed and submitted along with the answer paper for evaluation by the external examiner.

Part B: The program for the given component should be written in the answer paper. The program should be entered in the CNC machine and the component should be submitted for evaluation by the external examiner. The machined component should be kept under the custody of examiner.

Allocation of marks for Board Examination

PART A: Solid Modelling

Creation of sketch	: 15
Modelling	: 25
Accuracy	: 5

PART B: CNC Programming

Program writing	: 15
Setting	: 10
Editing and Machining	: 20
Viva voce	: 10

Total Marks : 100

LIST OF EQUIPMENTS (For 30 students)

1. Personal computer - 30 Nos.
2. 3D Solid Modelling and Simulation software - Sufficient to the strength
3. CNC Lathe –2 Nos.
4. CNC Mill –2 Nos.
5. Consumables - Sufficient quantity
6. Laser / Inkjet Printer – 1 No.

Blank Page

STATE BOARD OF TECHNICAL EDUCATION & TRAINING, TAMILNADU
DIPLOMA IN ENGINEERING / TECHNOLOGY SYLLABUS
N - SCHEME

(To be implemented for the students admitted from the year 2020 - 2021 onwards)

Course Name : 1020 Diploma in Mechanical Engineering
 Subject Code : 4020562
 Semester : V
 Subject Title : Green Energy and Energy Conservation Practical

TEACHING AND SCHEME OF EXAMINATION

No of weeks per semester: 16 weeks

Subject	Instructions		Examination			
	Hours / Week	Hours / Semester	Marks			Duration
Internal Assessment			Board Examinations	Total		
4020562 Green Energy and Energy Conservation Practical	4	64	25	100*	100	3 Hrs.

* Examinations will be conducted for 100 marks and it will be reduced to 75 marks for result.

Objectives:

- To demonstrate the I-V and P-V Characteristics of PV module .
- To show the effect of variation in tilt angle on PV module power.
- To study the characteristics of battery.
- To understand how a solar PV standalone system works
- To workout power flow calculations of standalone PV system AC load DC load with battery.
- To understand how to use various electrical measuring equipments.
- To study the different electrical parameters of a monocrystalline and polycrystalline silicon solar panel
- To study the effect of shading on the output of solar panel.
- To understand and determine the power flow in a solar DC system.

4020562 GREEN ENERGY AND ENERGY CONSERVATION PRACTICAL

DETAILED SYLLABUS

Experiments

PART A

1. Study and demonstrate the I-V and P-V Characteristics of PV module with varying radiation and temperature level.
2. Study and demonstrate the I-V and P-V characteristics of series and parallel combination of PV modules.
3. Study and demonstrate the effect of shading on module output power.
4. Do a shading analysis on the site where solar PV system needs to be setup.
5. Study the wind power generation status in Tamilnadu.
6. Study the biogas generation status in Tamilnadu.

PART B

1. Conduct experiment to show the effect of variation in tilt angle on PV module power.
2. Conduct the experiment to demonstrate the working of diode as Bypass diode and blocking diode.
3. Conduct the experiment to draw the charging and discharging characteristics of battery.
4. Conduct the experiment for the power flow calculations of standalone PV system of AC load with battery.
5. Conduct the experiment for the power flow calculations of standalone PV system of DC load with battery.
6. Conduct the experiment to determine the different electrical parameters of a monocrystalline and polycrystalline silicon solar panel.

BOARD EXAMINATION

Note:

- All the experiments in both sections should be completed. Two experiments will be given for examination by selecting one from PART A and one from PART B.
- All the experiments should be given in the question paper and students are allowed to select by a lot or Question paper issued from the DOTE should be followed.
- All regular students appearing for first attempt should submit record notebook for the examination.
- The external examiner should verify the availability of the facility for the batch strength before commencement of practical examination.
- The external examiner should verify the working condition of machinery's / equipment before commencement of practical examination.

ALLOCATION OF MARKS

Part - A		
Study explanation		: 30
Part - B		: 60
Procedure	15	
Observation / Reading / calculation	35	
Result	10	
Viva-voce		: 10
Total		: 100

Equipment / Tools Required (For 30 students)

S.No.	Description	Qty.
1	150 /160 Wp Polycrystalline Solar PV Modules	2 Nos.
2	340/350 Wp Mono crystalline Solar PV Modules	2 Nos.
3	80 / 90 Wp Thin film Solar PV Modules	2 Nos.
4	1000W/1500W Off-grid Grid Inverter with MPPT Charge Controller	1 No.
5	Solar Structure	1 No.
6	Wall mountable ACDB Box	1 No.
7	Earthing kit	3 No.
8	DC Wire , AC Wire, PVC items	1 No.
9	Accessories like MC4 connectors, Lugs, Screws etc	Sufficient quantity
10	Solar System Analyser	1 No.
11	Solar Power Meter	1 No.
12	Solar Module Analyser	1 No.
13	Thermal Imaging Camera	1 No.
14	Drill m/c, Multimeters, Clamp meters, Tools & Tackles, Safety gear	1 Set
15	Electrical Measuring Instruments	Sufficient Quantity
16	Shop Floor Tools	Sufficient Quantity

STATE BOARD OF TECHNICAL EDUCATION & TRAINING, TAMILNADU
DIPLOMA IN ENGINEERING / TECHNOLOGY SYLLABUS
N-SCHEME

(To be implemented for the students admitted from the year 2020 - 2021 onwards)

Course Name : 1020 Diploma in Mechanical Engineering
 Subject Code : 4020563
 Semester : V
 Subject Title : Mechatronics Practical

TEACHING AND SCHEME OF EXAMINATION

No. of Weeks per Semester: 16 Weeks

Subject	Instructions		Examination			
	Hours/ Week	Hours/ Semester	Marks			Duration
			Internal Assessment	Board Examination	Total	
4020563 Mechatronics Practical	4	64	25	100*	100	3Hrs.

*Examinations will be conducted for 100 marks and it will be reduced for 75 marks for result

RATIONALE:

As per the latest requirements in the Industries this enables to learn the various concepts of industrial automation. They are able to write ladder logic program and able operate PLCs. They are able to understand the advanced concepts adopted in industrial automation.

OBJECTIVES:

- Acquire knowledge in the field of mechatronics
- Explain the various components of electro pneumatics and electro hydraulics
- Handle PLC, HMI, SCADA and DCS components

4020563 MECHATRONICS PRACTICAL

DETAILED SYLLABUS

ELECTRO PNEUMATICS: Introduction to Electro Pneumatics -Applications of pneumatics - Pneumatic and electro pneumatic controllers - Components and assemblies in the electrical signal control section: Power supply unit - Push button and control switches - Sensors for measuring displacement and pressure - Relays and contactors. Electrically actuated directional control valves - Construction and mode of operation - Functions - Electrical connection of solenoid coils. Procedure for developing a control system.

ELECTRO HYDRAULICS: Basic principles of electro hydraulics - Function and use of electrohydraulic components - Production and interpretation of standard hydraulic and electrical circuit diagrams

PROCESS CONTROL INSTRUMENTATION: Process control - Types of processes – Structure of control system – Controllers - Digital controllers – Types of process control – ON/OFF Control – Analog control – Digital control. Data Acquisition System - Objectives of DAS - Types of DAS: Single channel DAS – Multichannel DAS – Computer based DAS. Data Loggers - Block diagram of Data Loggers – Control facilities in Data Logger – Uses of Data Logger - Different stages of Direct Digital Control.

SCADA - Fundamental principles of modern SCADA systems - SCADA hardware - SCADA software - Landlines for SCADA - SCADA and local area networks - Modem used in SCADA systems - Remote terminal units. Human Machine Interface – components of HMI.

Distributed Control System - Parts of DCS – Layered structure of DCS – Communication options in DCS. Variable Frequency Drives - Construction, Working, Operation, Applications and Specifications

Experiments

PART A

(ELECTRO PNEUMATICS)

1. Direct control of a 3/2 NC Single solenoid valve and a 3/2 NO Single solenoid valve
2. Direct control of a 5/2 single solenoid valve and a 5/2 double solenoid valve
3. Simple circuit using OR Logic and AND Logic
4. Limit switch and proximity switch application circuits

(ELECTRO HYDRAULICS)

1. Sorting device using double acting cylinder, directly actuated, manually
2. Component selection on conveyor belt using double acting cylinder and directly actuated, manually
3. Lifting station using single acting cylinder and directly actuated, manually
4. Door control using double acting cylinder and interlocking

PART B

PROCESS CONTROL INSTRUMENTATION

1. Wiring practice of HMI
2. Design of HMI screen
3. HMI Configuration and Interfacing with PLC and PC
4. Configuring Alarms in SCADA
5. Real time project development and interfacing with PLC
6. Monitoring & Control of Pneumatic System using HMI

BOARD EXAMINATION

Note:

1. All the experiments in both sections should be completed. Two experiments will be given for examination by selecting one from PART A and one from PART B.
2. All the experiments should be given in the question paper and students are allowed to select by a lot or Question paper issued from the DOTE should be followed.

3. All regular students appearing for first attempt should submit record notebook for the examination.
4. The external examiner should verify the availability of the facility for the batch strength before commencement of practical examination.
5. The external examiner should verify the working condition of machinery's / equipment before commencement of practical examination.

ALLOCATION OF MARKS

PART A: Electro Pneumatic circuit / Electro Hydraulic circuit (by lot):

Circuit diagram	:	15
Components connections & execution	:	20
Output	:	10

PART B: Process Control Instrumentation

Circuit diagram	:	15
Execution & Programming	:	20
Output	:	10
Vivavoce	:	10
Total Marks	:	100

List of Equipment (For 30 students)

Electro Pneumatics:

1. Basic Pneumatic Trainer Kit with FRL Unit, Compressor and Accessories – 2 Nos
 - 3/2 NC Single Solenoid Valve - 2Nos
 - 3/2 NO Single Solenoid Valve - 2Nos
 - 5/2 Single Solenoid Valve - 2Nos
 - 5/2 Double Solenoid Valve - 2Nos
 - Limit Switch – 6 Nos
 - Proximity Sensor (Inductive, Capacitive & Optical) – Each 2 Nos
 - Single Acting Pneumatic Cylinder – 4 Nos
 - Double Acting Pneumatic Cylinder – 2 Nos
 - Power Supply Unit, Connecting Leads and Hoses – As per Requirements

Electro Hydraulics:

1. Basic Hydraulics Trainer Kit with Hydraulic Pump, Regulator and Hoses

Accessories – 2 Nos

- Double Acting Cylinder – 2 Nos
- Single Acting Cylinder – 2 No
- Manual Actuator Switch – 4 Nos
- Material Sorting assembly set up – 1 No
- Conveyor Assembly set up – 1 No
- Lifting Station Assembly Set up – 1 No
- Limit Switch - 4 Nos

Process Control Instrumentation:

- Programmable Logic Controller (PLC) with Software – 3 Nos
- Human Machine Interface (HMI) with Software - 3 Nos
- SCADA Software – 1 No or Integrated Software for PLC, HMI and SCADA)
- Personnel Computer – 3 Nos
- Water Tank Assembly set up with Level Sensor and Flow Controller (Actuator) to interface with PLC and HMI – 1 No

Blank Page

STATE BOARD OF TECHNICAL EDUCATION & TRAINING, TAMILNADU
DIPLOMA IN ENGINEERING / TECHNOLOGY SYLLABUS
N-SCHEME
(implemented from the Academic year 2020-2021 onwards)

Course Name : 1020 Diploma in Mechanical Engineering

Subject Code : 4020570

Semester : V

Subject Title : Entrepreneurship & Startups

TEACHING AND SCHEME OF EXAMINATION

No. of Weeks per Semester: 16 Weeks

Subject	Instructions		Examination			
	Hours/ Week	Hours/ Semester	Marks			Duration
			Internal Assessment	Board Examination	Total	
4020570 Entrepreneurship & Startups	4	64	25	100*	100	3 Hrs.

*Examinations will be conducted for 100 marks and it will be reduced for 75 marks for result

Topics and Allocation of Hours

UNIT	Topic	Hours
1	Entrepreneurship – Introduction and Process	10
2	Business Idea and Banking	10
3	Start ups, E-cell and Success Stories	10
4	Pricing and Cost Analysis	10
5	Business Plan Preparation	10
Field visit and Preparation of case study report		14
Total		64

RATIONALE:

Development of a diploma curriculum is a dynamic process responsive to the society and reflecting the needs and aspiration of its learners. Fast changing society deserves changes in educational curriculum particularly to establish relevance to emerging socio-economic environments; to ensure equity of opportunity and participation and finally promoting concern for excellence. In this context the course on entrepreneurship and start ups aims at instilling and stimulating human urge for excellence by realizing individual potential for generating and putting to use the inputs, relevant to social prosperity and thereby ensure good means of living for every individual, provides jobs and develop Indian economy.

OBJECTIVES:

At the end of the study of 5th semester the students will be able to

- To excite the students about entrepreneurship
- Acquiring Entrepreneurial spirit and resourcefulness
- Understanding the concept and process of entrepreneurship
- Acquiring entrepreneurial quality, competency and motivation
- Learning the process and skills of creation and management of entrepreneurial venture
- Familiarization with various uses of human resource for earning dignified means of living
- Know its contribution in and role in the growth and development of individual and the nation
- Understand the formation of E-cell
- Survey and analyze the market to understand customer needs
- Understand the importance of generation of ideas and product selection
- Learn the preparation of project feasibility report
- Understand the importance of sales and turnover
- Familiarization of various financial and non financial schemes
- Aware the concept of incubation and starts ups

DETAILED SYLLABUS

Unit	Name of the Topics	Hours
1	<p>ENTREPRENEURSHIP – INTRODUCTION AND PROCESS</p> <ul style="list-style-type: none"> • Concept, Functions and Importance • Myths about Entrepreneurship • Pros and Cons of Entrepreneurship • Process of Entrepreneurship • Benefits of Entrepreneur • Competencies and Characteristics • Ethical Entrepreneurship • Entrepreneurial Values and Attitudes • Motivation • Creativity • Innovation • Entrepreneurs - as problem solvers • Mindset of an employee and an entrepreneur • Business Failure – causes and remedies • Role of Networking in entrepreneurship 	10
2	<p>BUSINESS IDEA AND BANKING</p> <ul style="list-style-type: none"> • Types of Business: Manufacturing, Trading and Services • Stakeholders: Sellers, Vendors and Consumers • E- Commerce Business Models • Types of Resources - Human, Capital and Entrepreneurial tools • Goals of Business and Goal Setting • Patent, copyright and Intellectual Property Rights • Negotiations - Importance and methods • Customer Relations and Vendor Management • Size and Capital based classification of business enterprises • Role of Financial Institutions • Role of Government policy 	10

	<ul style="list-style-type: none"> • Entrepreneurial support systems • Incentive schemes for State Government • Incentive schemes for Central Government 	
3	STARTUPS, E-CELL AND SUCCESS STORIES <ul style="list-style-type: none"> • Concept of Incubation centre's • Activities of DIC, financial institutions and other relevance institutions • Success stories of Indian and global business legends • Field Visit to MSME's • Various sources of Information • Learn to earn • Startup and its stages • Role of Technology – E-commerce and Social Media • Role of E-Cell • E-Cell to Entrepreneurship 	10
4	PRICING AND COST ANALYSIS <ul style="list-style-type: none"> • Calculation of Unit of Sale, Unit Price and Unit Cost • Types of Costs - Variable and Fixed, Operational Costs • Break Even Analysis • Understand the meaning and concept of the term Cash Inflow and Cash Outflow • Prepare a Cash Flow Projection • Pricing and Factors affecting pricing • Understand the importance and preparation of Income Statement • Launch Strategies after pricing and proof of concept • Branding - Business name, logo, tag line • Promotion strategy 	10
5	BUSINESS PLAN PREPARATION <ul style="list-style-type: none"> • Generation of Ideas, • Business Ideas vs. Business Opportunities 	10

	<ul style="list-style-type: none"> • Selecting the Right Opportunity • Product selection • New product development and analysis • Feasibility Study Report – Technical analysis, financial analysis and commercial analysis • Market Research - Concept, Importance and Process • Marketing and Sales strategy • Digital marketing • Social Entrepreneurship • Risk Taking-Concept • Types of business risks 	
--	--	--

REFERENCE BOOKS:

1. Dr. G.K. Varshney, Fundamentals of Entrepreneurship, Sahitya Bhawan Publications, Agra - 282002
2. Dr. G.K. Varshney, Business Regulatory Framework , Sahitya Bhawan Publications, Agra - 282002
3. Robert D. Hisrich, Michael P. Peters, Dean A. Shepherd, Entrepreneurship , McGraw Hill (India) Private Limited, Noida - 201301
4. M.Scarborough, R.Cornwell, Essentials of Entrepreneurship and small business management, Pearson Education India, Noida - 201301
5. Charantimath Poornima M. Entrepreneurship Development and Small Business Enterprises, Pearson Education, Noida - 201301
6. Trott, Innovation Management and New Product Development, Pearson Education, Noida - 201301
7. M N Arora, A Textbook of Cost and Management Accounting, Vikas Publishing House Pvt. Ltd., New Delhi-110044
8. Prasanna Chandra, Financial Management, Tata McGraw Hill education private limited, New Delhi
9. I. V. Trivedi, Renu Jatana, Indian Banking System, RBSA Publishers, Rajasthan
10. Simon Daniel, HOW TO START A BUSINESS IN INDIA, BUUKS, Chennai - 600018

11. Ramani Sarada, The Business Plan Write-Up Simplified - A practitioners guide to writing the Business Plan, Notion Press Media Pvt. Ltd., Chennai 600095.

Board Examination – Evaluation Pattern

Internal Mark Allocation

Assignment (Theory portion)*	-	10
Seminar Presentation	-	10
Attendance	-	5
Total	-	25

Note: * Two assignments should be submitted. The same must be evaluated and converted to 10 marks.

Guidelines for assignment:

First assignment – Unit I

Second assignment – Unit II

Guidelines for Seminar Presentation - Unit III

Each assignment should have five three marks questions and two five marks questions.

BOARD EXAMINATION

Note

1. The students should be taught all units and proper exposure and field visit also arranged. All the portions should be completed before examinations.
2. The students should maintain theory assignment and seminar presentation. The assignment and seminar presentation should be submitted during the Board Practical Examinations.
3. The question paper consists of theory and practical portions. All students should write the answers for theory questions (45 Marks)

and practical portions (55 Marks) should be completed for board examinations.

4. All exercises should be given in the question paper and students are allowed to select by lot. If required the dimensions of the exercises may be varied for every batch. No fixed time allotted for each portion and students have liberty to do the examination for 3Hrs.
5. For Written Examination: theory question and answer: 45 Marks
 Ten questions will be asked for 3 marks each. Five questions from each unit 1 & 2. (10 X 3 = 30).
 Three questions will be asked for 5 marks each. One question from each unit 1, 2 & 3. (3 X 5 = 15)
6. For Practical Examination: The business plan/Feasibility report or Report on Unit 4 & 5 should be submitted during the board practical examinations. The same have to be evaluated for the report submission (40 marks).

DETAILED ALLOCATION OF MARKS

Sl. No	Description	Marks
Part A	Written Examination - Theory Question and answer 10 questions x 3 marks = 30 marks 3 questions x 5 marks = 15 marks	45
Part B	Practical Examination – Submission on Business Plan/Feasibility Report or Report on Unit 4 & 5	40
Part C	Viva voce	15
	Total	100

Blank Page

STATE BOARD OF TECHNICAL EDUCATION & TRAINING, TAMILNADU
DIPLOMA IN ENGINEERING / TECHNOLOGY SYLLABUS
N - SCHEME

(To be implemented for the students admitted from the year 2020 - 2021 onwards)

Course Name : 1020 Diploma in Mechanical Engineering

Subject Code : 4020610

Semester : VI

Subject Title : Industrial Engineering and Management

TEACHING AND SCHEME OF EXAMINATION

No of weeks per semester: 16 weeks

Subject	Instructions		Examination			
	Hours / Week	Hours / Semester	Marks			Duration
Internal Assessment			Board Examinations	Total		
4020610 Industrial Engineering and Management	6	96	25	100*	100	3 Hrs.

* Examinations will be conducted for 100 marks and it will be reduced to 75 marks for result.

Topics and Allocation of Hours:

Unit No	Topics	Hours
I	Plant Engineering and Plant Safety	18
II	Work Study, Method Study and Work Measurement	18
III	Principles, Personnel Management and Organizational Behavior:	19
IV	Financial and Material Management	18
V	Engineering Ethics and Human Values	16
Test and Model Exam		07
Total		96

RATIONALE:

In the Indian Economy, Industries and Enterprises always find prominent place. After globalization, the students should be trained not only in manufacturing process but also in managing activities of industries. The knowledge about plant, safety, work study techniques, personnel management, financial management and engineering ethics and human values will definitely help the students as managers to suit the industries.

OBJECTIVES:

- To study the different types of layout.
- To study the safety aspects and its impacts on an organization.
- To study different work measurement techniques.
- To study engineering ethics and human values.
- To study the staff selection procedure and training of them.
- To study capital and resources of capital.
- To study inventory control system.
- To study about organization and it's behavior.

4020610 INDUSTRIAL ENGINEERING AND MANAGEMENT DETAILED SYLLABUS

Contents: Theory

Unit	Name of the Topics	Time
I	Plant Engineering and Plant Safety	
	Chapter: 1.1: Plant Engineering : Plant – Selection of site of industry – Plant layout – Principles of a good layout – types – process, product and fixed position – techniques to improve layout – Principles of material handling equipment – Plantmaintenance – importance – Break down maintenance, preventive maintenance and scheduled maintenance.	9
	Chapter: 1.2: Plant Safety: Importance – accident - causes and cost of an accident - accident proneness - prevention of accidents - Industrial disputes - settlement of Industrial disputes - Collective bargaining, conciliation, Mediation, arbitration - Indian Factories Act 1948 and its provisions related to health, welfare and safety.	9

<p>II</p>	<p>Work Study, Method Study and Work Measurement</p> <p>Chapter: 2.1: Work Study: Productivity – Standard of living – method of improving productivity – Objectives – Importance of good working conditions.</p> <p>Chapter: 2.2: Method Study: Definition – Objectives – Selection of a job for method study – Basic procedure for conduct of method study – Tools used – Operation process chart, Flow process chart, two handed process chart, Man Machine chart, String diagram and flow diagram.</p> <p>Chapter: 2.3: Work Measurement: Definition – Basic procedure in making a time study – Employees rating factor – Application of time allowances – Rest, Personal, Process, Special and Policy allowances – Calculation of standard time – Problems – Basic concept of production study – Techniques of work measurement - Ratio delay study, Synthesis from standard data, analytical estimating and Pre determined Motion Time System (PMTS).</p>	<p>4</p> <p>6</p> <p>8</p>
<p>III</p>	<p>Principles, Personnel Management and Organizational Behavior:</p> <p>Chapter: 3.1: Principles of Management: Definition of management – Administration - Organization – F.W. Taylor’s and Henry Fayol’s Principles of Management – Functions of Manager – Directing – Leadership –Types of Leadership – Qualities of a good leader – Motivation – Positive and negative motivation - Modern management techniques- Management Information Systems – Strategic management – SWOT Analysis - Business Process Re-engineering (BPR) – Enterprises Resource Planning (ERP) – Activity Based Management (ABM) – Global Perspective – Principles and brief description.</p> <p>Chapter: 3.2: Personnel Management: Responsibility of human resource management – Selection procedure – Training of workers – Apprentice training – On the job training and vestibule school training – Job evaluation and merit rating – objectives and importance – wages and salary administration – Components of wages – Wage fixation – Type of wage payment – Halsey’s 50% plan,</p>	<p>7</p> <p>7</p>

	<p>Rowan's plan and Emerson's efficiency plan – Problems.</p> <p>Chapter: 3.3: Organizational behavior: Definition – organization - Types of Organization – Line, Staff, Taylor's Pure functional types – Line and staff and committee type – Organizational Approaches, individual behavior - causes - Environmental effect - Behavior and Performance, Perception - organizational implications.</p>	5
IV	<p>Financial and Material Management</p> <p>Chapter: 4.1: Financial Management: Fixed and working capital – Resources of capital – shares preference and equity shares – debentures – Type of debentures – Public deposits, Factory costing – direct cost – indirect cost – Factory overhead – Selling price of a product – Profit – Problems. Depreciation – Causes – Methods - Straight line, sinking fund and percentage on diminishing value method – Problems.</p> <p>Chapter: 4.2: Material Management: Objectives of good stock control system – ABC analysis of inventory – Procurement and consumption cycle – Minimum Stock, Lead Time, Reorder Level - Economic order quantity - problems – supply chain management - Introduction – Purchasing procedure – Store keeping – Bin card.</p>	9 9
V	<p>Engineering Ethics and Human Values</p> <p>Chapter: 5.1: Engineering Ethics: Definition - engineering ethics - personal and business ethics - duties and rights - engineering as a profession - core qualities of professional practitioners - environment and their impact - code of ethics - procedure for solving ethical conflicts - ethical judgement - Kohiberg's stages of moral development - value based ethics - engineers as managers, consultants and leaders - environmental ethics - computer ethics - Intellectual Property Rights (IPRs).</p> <p>Chapter: 5.2: Human values : Morals – values – integrity - service learning - civic virtue - respect for others - living peacefully - caring – sharing – honesty - courage - valuing time cooperation - commitments – empathy - selfconfidence – character - stress management.</p>	9 7

Reference Books :

1. Industrial Engineering and Management, O.P. Khanna, Revised Edition Publications (P) Ltd – 2004, 67/4 Madras House, Daryaganj, New Delhi– 110002.
2. Engineering Economics and Management, T.R. Banga& S.C. Sharma, McGraw Hill Edition. 2 – 2001, New Delhi.
3. Herald Koontz and Heinz Wehrich, Essentials of Management, McGraw Hill Publishing Company, Singapore International Edition. Latest
4. Govindarajan .M, Natarajan. S, Senthilkumar V.V, Engineering ethics, prentice hall of India New Delhi, 2004.
5. Management, Aglobal perspective, Heinz Wehrich, Harold Koontz, 10th Edition, McGraw Hill International Edition. Latest.
6. Essentials of Management,4th Edition, Joseph L. Massie, Prentice - Hall of India, New Delhi 2004.
7. S.Chandran, Organizational Behaviours, Vikas Publishing House Pvt. Ltd. Latest
8. M.Govindarajan and S.Natarajan, Principles of Management, Prentce Hall of India Pvt.Ltd. New Delhi. Latest.
9. Charles B. Fledderman, Engineering ethics, pearson prentice hall, New Jersey, 2004.

Blank Page

**STATE BOARD OF TECHNICAL EDUCATION & TRAINING, TAMILNADU
DIPLOMA IN ENGINEERING / TECHNOLOGY SYLLABUS**

N - SCHEME

(To be implemented for the students admitted from the year 2020 - 2021 onwards)

Course Name : 1020 Diploma in Mechanical Engineering

Subject Code : 4020620

Semester : VI

Subject Title : E Vehicle Technology & Policy

TEACHING AND SCHEME OF EXAMINATION

No of weeks per semester: 16 weeks

Subject	Instructions		Examination			
	Hours / Week	Hours / Semester	Marks			Duration
Internal Assessment			Board Examinations	Total		
4020620 E Vehicle Technology & Policy	4	64	25	100*	100	3 Hrs.

* Examinations will be conducted for 100 marks and it will be reduced to 75 marks for result.

Topics and Allocation of Hours

Unit No	Topics	Hours
I	Environmental impact and history, Types of Electric vehicles	12
II	Electric vehicle, Electrical Propulsion System	12
III	Energy Storages, Charging System, Effects and Impacts	11
IV	Electric Mobility Policy Frame Work	11
V	Tamilnadu E-Vehicle Policy 2019	11
Test and Model Exam		7
Total		64

RATIONALE:

The world is transitioning to cleaner mobility options with the aim at improving air quality and reducing dependency on fossil fuels. Electric Vehicles (EVs) have emerged a popular clean mobility choice to reduce emissions. EVs are powered fully or partially by batteries, they can help to reduce dependence on fossil fuels also air quality. Tamil Nadu is one of the most advanced states in India. Tamil Nadu has a highly developed industrial eco-system and is very strong in sectors like automobiles and auto-components. Many globally renowned companies have setup their manufacturing facilities in Tamil Nadu. Due the rapid depletion of fossil fuel and increase in fuel cost, environmental pollution, the shift to clean transport is necessary. This subject introduced by keeping all the above factors.

OBJECTIVES:

- To learn the environmental impact and history of Electric Vehicles.
- To understand the concept of Electric Vehicle and its types.
- To study the configurations of Electric Vehicles
- To acquire knowledge about Energy Storages, Charging System, Effects and Impacts
- To appreciate the Electric Mobility Policy Frame work India and EV Policy Tamil Nadu 2019.

4020620 E Vehicle Technology & Policy

DETAILED SYLLABUS

Contents: Theory

Unit	Name of the Topics	Hours
I	Environmental impact and history: Environmental impact of conventional vehicle - Air pollution – Petroleum resources – History of Electric vehicles & Hybrid Electric Vehicles - Conventional drive train system – Rear Wheel, Front Wheel and All wheel - Parts of Drive train system	6
	Types of Electric Vehicles: Introduction to Battery Electric Vehicle (BEV) – Definition BEV – Necessity BEV – Different between BEV and Conventional Vehicle -	6

	Scope and Applicability of EV Policy – ARAI Standards for Electric Vehicle – AIS 038, AIS 039 & AIS 123 - Key Performance Indicator - Global impact – Trends and Future Developments	
V	Tamil Nadu E-Vehicle Policy 2019 Tamil Nadu E-vehicle Policy 2019: Vehicle Population in Tamil Nadu – Objectives of EV Policy – Policy Measures – Demand side incentives – Supply side incentives to promote EV manufacturing – Revision of Transport Regulation of EV – City building codes – Capacity Building and Skilling – Charging structure – implementing agencies – Research & Development and Business Incubation – Recycling Ecosystem – Battery and EVs	11

Reference Books

1. Modern Electric, Hybrid Electric and Fuel Cell Vehicles, Mehrdad Ehsani, Yimin Gao, Sebastien E. Gay, Ali Emadi, CR Press, London, New York.
2. Comparison of Electric and Conventional Vehicles in Indian Market: Total Cost of Ownership, Consumer Preference and Best Segment for Electric Vehicle (IJSR), Akshat Bansal, Akriti Agarwal
3. A Comprehensive Study of Key Electric Vehicle (EV) Components, Technologies, Challenges, Impacts, and Future Direction of Development (MDPI), Fuad Un-Noor, Sanjeevikumar Padmanaban, Lucian Mihet-Popa, Mohammad Nurunnabi Mollah and Eklas Hossain.
4. Electric Vehicles: A future Projection CII October 2020 report.
5. Design and analysis of aluminum/air battery system for electric vehicles, Shaohua Yang, Harold Knickle, Elsevier.
6. Propelling Electric Vehicles in India, Technical study of Electric Vehicles and Charging Infrastructure
7. ZERO EMISSION VEHICLES (ZEVs): TOWARDS A POLICY FRAMEWORK – NTI Aayog.
8. FASTER ADOPTION OF ELECTRIC VEHICLES IN INDIA: PERSPECTIVE OF CONSUMERS AND INDUSTRY, The Energy and Resources Institute, New Delhi.
9. India EV Story: Emerging Opportunities by Innovation Norway.
10. Automotive Industry Standards – AIS 038, AIS 039 & AIS 123 – Manual

**STATE BOARD OF TECHNICAL EDUCATION & TRAINING, TAMILNADU
DIPLOMA IN ENGINEERING / TECHNOLOGY SYLLABUS**

N – SCHEME

(To be implemented for the students admitted from the year 2020 – 2021 onwards)

Course Name : 1020 Diploma in Mechanical Engineering

Subject Code : 4020631

Semester : VI

Subject Title : Industrial Robotics and 3D Printing

TEACHING AND SCHEME OF EXAMINATION

No of weeks per semester: 16 weeks

Subject	Instructions		Examination			
	Hours / Week	Hours / Semester	Marks			Duration
Internal Assessment			Board Examinations	Total		
4020631 Industrial Robotics and 3D Printing	5	80	25	100*	100	3 Hrs.

* Examinations will be conducted for 100 marks and it will be reduced to 75 marks for result.

Topics and Allocation of Hours:

Unit No	Topics	Hours
I	Fundamentals of Robot Technology	12
II	Drive Systems, End Effecters, Sensors and Machine Vision System	12
III	Robot Programming, Robot Applications in Manufacturing	12
IV	Introduction and Design for Additive Manufacturing	18
V	Additive Manufacturing Processes	19
Test and Model Exam		07
Total		80

RATIONALE:

Rapid industrialization and globalization needs industries to be more competitive and deliver cost effective quality products. This needs industries to implement flexible manufacturing systems where Robotic technology plays major role. Hence study of robotic technology is very essential.

3D printing is often utilized when manufacturers need to create a product accurately, quickly and at a low quantity. This has lead to 3D printers being brought in to prototype industrial robots, helping to aid the development of better, more efficient robots in the industrial sector.

OBJECTIVES:

- Understand fundamentals of robotics
- Acquire knowledge structure and elements of robot
- Gain knowledge on controller and various drives used in robotics
- Develop knowledge on role of sensors and vision system
- Acquire skill to program and control robot
- Understand to adopt robot to various industrial applications.
- To acquire the knowledge on 3D Printing and design principles for additive manufacturing
- To understand the principles of latest manufacturing processes in Additive manufacturing

4020631 Industrial Robotics and 3D Printing DETAILED SYLLABUS

Contents: Theory

Unit	Name Of The Topic	Hours
I	Fundamentals of Robot Technology Introduction – History of robot– Definitions– Basic configuration of Robotics – Robot Components – Manipulator, End effector, Driving system, Controller and Sensors – Degrees of freedom – Links and joints – Types of joints – Joint notation scheme – Pitch, Yaw, Roll – Classification of robots – Work envelope and Work Volume – Effect of structure on Control ,Work envelop and Work volume- Introduction to PUMA robot- Robot controller –	12

	Configuration - Four types of controls – Open loop and closed loop controls – Speed of response and stability – Precision of movements: Spatial resolutions, accuracy and repeatability.	
II	<p>Drive Systems, End Effecters, Sensors and Machine Vision System</p> <p>Pneumatic drives – Hydraulic drives – Mechanical drives – Electrical drives – Stepper motors, DC Servo motors and AC Servo motors– Applications and Comparisons of Drives. End effecters – Grippers – Mechanical Grippers, Magnetic Grippers, Vacuum Grippers- Selection and design considerations in robot gripper- Requirements of Sensors – Position sensors: LVDT, Resolvers, Optical encoders- Proximity sensors: Inductive, Capacitive, Ultrasonic and Optical proximity sensors- Touch Sensors – Range Sensors- Machine Vision System: Sensing & Digitizing Image Data – Image Processing and Analysis - Application</p>	12
III	<p>Robot Programming, Robot Applications In Manufacturing</p> <p>Forward kinematics, Inverse kinematics and differences – Forward kinematics and Reverse kinematics of manipulators with Two and Three degrees of freedom – Derivations. Robot programming –Lead through programming, Textual programming – Teach Pendant for Robot system– Robot programming languages – Motion commands, Sensor commands, End effector commands. Robot applications – Material handling-Spot welding – Arc welding – Spray painting – Assembling – Finishing-AGV-RGV.</p>	12
IV	<p>Introduction and Design for Additive Manufacturing</p> <p>Introduction to Additive Manufacturing</p> <p>Additive Manufacturing – 3D Printing – Rapid prototyping – Overview – Need – Additive manufacturing Vs CNC Machining - Development of Additive Manufacturing Technology – Principle of AM Process – Generalised Additive Manufacturing Process Chain - Classification - Benefits – Direct and Indirect process, Prototyping, Manufacturing and Tooling</p>	9

	<p>Design for Additive Manufacturing</p> <p>Design tools: Data processing - CAD model preparation – STL file - Part orientation and support structure generation - Model slicing - Tool path generation. Design for Additive Manufacturing: Concepts and objectives - AM unique capabilities - DFAM for part quality improvement – strategies – Design Rules – Quality aspects – Software for AM – MIMICS, etc.</p>	9
V	<p>Additive Manufacturing Processes</p> <p>Photo polymerization and Powder Bed Fusion Processes</p> <p>Photo polymerization: SLA - Photo curable materials - Process - reaction rates – scan patterns - Advantages and Applications. Powder Bed Fusion: SLS - Process description - powder fusion mechanism – material feed system - Process Parameters - Materials and Applications. Electron Beam Melting</p>	7
	<p>Extrusion Based And Sheet Lamination Processes</p> <p>Extrusion Based System: FDM – Introduction - Basic Principle – plotting and path control - Materials - Applications and Limitations - Bio-extrusion. Sheet Lamination Process: LOM – Materials - Gluing or Adhesive bonding - Thermal bonding – Ultrasonic AM.</p>	5
	<p>Printing Processes And Beam Deposition Processes</p> <p>Droplet formation technologies - Continuous mode - Drop on Demand mode - Three Dimensional Printing – Advantages – Bio- plotter - Beam Deposition Process: LENS- Process description - Material delivery - Process parameters – Materials – Benefits.Applications of AM technologies in Automotive, Manufacturing, Architectural, Healthcare, and Consumer products.</p>	7

Reference Books:

1. Industrial Robotics – Technology, Programming and Applications, P.Groover, MCGraw Hill, 2001
2. Chua C.K., Leong K.F., and Lim C.S., “Rapid prototyping: Principles and applications”, Third edition, World Scientific Publishers, 2010.

3. Ian Gibson, David W. Rosen, Brent Stucker “Additive Manufacturing Technologies: Rapid Prototyping to Direct Digital Manufacturing” Springer, 2010.
4. Robotics Control, Sensing, Vision and Intelligence, Fu.K.S.Gonzalez.R.C., and Lee C.S.G, McGraw-Hill Book Co., 1987
5. Robotics for Engineers, Yoram Koren, McGraw-Hill Book Co., 1992
6. Robotics and Image Processing, Janakiraman.P.A, Tata McGraw-Hill, 1995
7. Andreas Gebhardt “Understanding Additive Manufacturing: Rapid Prototyping, Rapid Manufacturing” Hanser Gardner Publication 2011.
8. Kamrani A.K. and Nasr E.A., “Rapid Prototyping: Theory and practice”, Springer, 2006.
9. Liou L.W. and Liou F.W., “Rapid Prototyping and Engineering applications: A tool box for prototype development”, CRC Press, 2007.
10. Tom Page, “Design for Additive Manufacturing” LAP Lambert Academic Publishing, 2012.
11. Amit Bandyopadhyay, and Susmita Bose, “Additive Manufacturing”, CRC Press.
12. John O Milewski., “Additive Manufacturing of Metals: From Fundamental Technology to Rocket Nozzles, Medical Implants, and Custom Jewellery”, Springer Series in Materials Science
13. Sabrie Soloman. “Additive Manufacturing: Advanced Manufacturing Technology in 3d Print Deposit”
14. David Ian Wimpenny and Pulak M Pandey, “Advances in 3D Printing and Additive Manufacturing Technologies”
15. Andreas Gebhardt, Hanser, “Understanding Additive Manufacturing”

Blank Page

STATE BOARD OF TECHNICAL EDUCATION & TRAINING, TAMILNADU
DIPLOMA IN ENGINEERING / TECHNOLOGY SYLLABUS
N - SCHEME

(To be implemented for the students admitted from the year 2020 - 2021 onwards)

Course Name : 1020 Diploma in Mechanical Engineering

Subject Code : 4020632

Semester : VI

Subject Title : Refrigeration and Air-Conditioning

TEACHING AND SCHEME OF EXAMINATION

No of weeks per semester: 16 weeks

Subject	Instructions		Examination			
	Hours / Week	Hours / Semester	Marks			Duration
Internal Assessment			Board Examinations	Total		
4020632 Refrigeration and Air-Conditioning	5	80	25	100*	100	3 Hrs.

* Examinations will be conducted for 100 marks and it will be reduced to 75 marks for result.

Topics and Allocation of Hours:

Unit No	Topics	Hours
I	Refrigeration System And Refrigeration Equipments	15
II	Vapour Compression Refrigeration System And Vapour Absorption Refrigeration System	15
III	Refrigerant Flow Controls, Refrigerants And Lubricants, Applications Of Refrigeration	15
IV	Psychrometry And Comfort Air Conditioning	14
V	Air Conditioning Systems And Cooling Load Calculations	14
	Test and Model Exam	7
	TOTAL	80

RATIONALE:

Requirement of human comfort, maintenance of machines and preserving Perishables through air conditioning is very essential. Hence learning the study of refrigeration principles, refrigeration system, Concept of air-conditioning and methods of facilitates quality design of air conditioners are essential.

OBJECTIVES:

- Explain the working of open and closed air system of refrigeration.
- Describe the working and construction of compressors used for air-conditioning
- Explain the vapour compression refrigeration system.
- Explain the vapour absorption refrigeration system.
- Compare the properties and applications of various refrigerants.
- Define the parameters used for air conditioning.
- To Use the psychometric chart.
- Estimate the cooling load for the given requirement.
- Explain the industrial application of refrigeration.

4020632 REFRIGERATION AND AIR-CONDITIONING DETAILED SYLLABUS

Unit	Name Of The Topic	Hours
I	<p>REFRIGERATION SYSTEM</p> <p>Thermodynamic state of a pure substances - modes of heat transfer – laws of heat transfer – mechanisms of production of cold – unit of refrigeration – types of refrigeration – reversed Carnot cycle-C.O.P of heat engine–heat pump– refrigerating machine – principle of working of open and closed air system of refrigeration – Advantages and disadvantages – problems.</p> <p>REFRIGERATION EQUIPMENTS</p> <p>Compressor – principle of working and constructional details of reciprocating and rotary compressors, hermetically and semihermetically sealed compressors – condensers – principle of working and constructional details of air cooled and water cooled</p>	15

	<p>Condensers, evaporative condensers - advantages and disadvantages - natural and forced draught cooling towers. Evaporators – natural circulation and forced circulation type - principle of working constructional details.</p>	
II	<p>VAPOUR COMPRESSION REFRIGERATION SYSTEM</p> <p>Principle of working of vapour compression system – analysis of vapour compression cycle using T-s diagram and p-H diagram- refrigerating effect - compression work – C.O.P – effect of superheating and under cooling – problems – effect of evaporative pressure – condenser pressure – liquid – vapour refrigeration heat exchangers – advantages and disadvantages of superheating and Under cooling – use of flash chamber and accumulator.</p> <p>VAPOUR ABSORPTION REFRIGERATION SYSTEM</p> <p>Simple absorption system – Electrolux system – Solar absorption system - absorption system comparison with Mechanical (Compression) refrigeration system.</p>	15
III	<p>REFRIGERANT FLOW CONTROLS, REFRIGERANTS AND LUBRICANTS AND APPLICATION OF REFRIGERATION</p> <p>Capillary tube - automatic expansion valve – thermostatic expansion valve - solenoid valve - evaporator pressure regulator – suction pressure regulator - selection of a refrigerant - properties and Applications of following refrigerants SO₂, CH₄, F11, F12, F22, and NH₃ – lubricants used in refrigeration and their applications, Cryogenics.</p> <p>APPLICATIONS OF REFRIGERATION</p> <p>Slow freezing – quick freezing – cold storage – frozen storage freeze drying – dairy refrigeration – ice cream cabinets – ice making – Water cooler, milk cooler, bottle cooler – frost free refrigeration.</p>	15
IV	<p>PSYCHROMETRY AND COMFORT AIR CONDITIONING</p> <p>Definitions of dry air, moist air, water vapour, Avogadro's law, Dalton's law of partial pressure – dry and wet bulb temperature -</p>	14

	dew point – humidity – specific and absolute – relative humidity - degree of saturation – enthalpy of moist air - adiabatic saturation of air by evaporation of water – psychometric chart and its uses – psychometric processes – sensible heating and cooling – humidifying and heating – dehumidifying and cooling – adiabatic cooling with humidification – total heating or cooling processes – sensible heat factor – by pass factor with simple problems – Governing optimum effective temperature – comfort chart - design consideration.	
V	<p>AIR CONDITIONING SYSTEMS</p> <p>Equipment for air conditioning and insulation factors – airpurification – temperature control – humidity control – dry and wet filters - centrifugal dust collector – air washer humidifier – dehumidifier – fans and blowers – grills and registers – summer and winter air conditioning, window type air conditioner – split type air conditioner system – properties of ideal insulator, types of insulating materials – air distribution and duct systems – tools and Installation, servicing and maintenance of R & AC systems.</p> <p>COOLING LOAD CALCULATIONS</p> <p>Different heat sources – conduction heat load – radiation Load of sun – occupants load – equipment load – infiltration air load – miscellaneous heat sources – fresh air load – simple problems.</p>	14

Reference books:

1. Refrigeration and air conditioning, P.L. Ballaney, Khanna Publishers, 2B, North Market, Naisarak, New Delhi 110 006.
2. Refrigeration and air conditioning, V.K. Jain,
3. Industrial Refrigeration Hand Book, Wilbert F. Steocker
4. A course in refrigeration and air conditioning, Domkundwar,
5. Principles of refrigeration, Dossat ,
6. Home refrigeration and air conditioning, Audels, Theo. Audel & Co. publisher, 199 Edn. 49, West 23rd Street, New York. – 1998
7. Refrigeration and air conditioning, C.P Arora,
8. Cryogenic systems Randell Fd Barron.

**STATE BOARD OF TECHNICAL EDUCATION & TRAINING, TAMILNADU
DIPLOMA IN ENGINEERING / TECHNOLOGY SYLLABUS**

N – SCHEME

(To be implemented for the students admitted from the year 2020 – 2021 onwards)

Course Name : 1020 Diploma in Mechanical Engineering

Subject Code : 4020633

Semester : VI

Subject Title : Automobile Technology

TEACHING AND SCHEME OF EXAMINATION

No of weeks per semester: 16 weeks

Subject	Instructions		Examination			Duration
	Hours / Week	Hours / Semester	Marks			
Internal Assessment			Board Examinations	Total		
4020633 Automobile Technology	5	80	25	100*	100	3 Hrs.

* Examinations will be conducted for 100 marks and it will be reduced to 75 marks for result.

Topics and Allocation of Hours:

Unit No	Topics	Hours
I	Automobile Engines	14
II	Fuel Feed Systems and Alternative fuels	14
III	Transmission and Power Trains	15
IV	Automobile Chassis	15
V	Electrical Equipment & Hybrid Electric Vehicles	15
Test and Model Exam		07
Total		80

RATIONALE:

Automobile is one of the key areas of development in India facilitated by Multinational Companies. As Automobile is the Major sources of employing man power a thorough knowledge on Automobile Engine construction and its functioning is required with due consideration on pollution control.

OBJECTIVES:

- Explain about the constructional details of an Automobile engine including cooling and lubrication system.
- Describe fuel feed systems for petrol and diesel engines with all devicesinvolved in it.
- Explain the construction and functional features of the power transmission systems and various parts involved in it.
- Explain the functions of different types of steering, suspension and brake systems.
- Describe the different types of chassis and their functions.
- Familiarize electrical and electronic equipments used in automobile.
- To understand the emerging trends of electric vehicles, hybrid electric vehicles and solar vehicles.
- To know the automobile emissions and its effects on environment.

**4020633 AUTOMOBILE TECHNOLOGY
DETAILED SYLLABUS**

Contents: Theory

Unit	Name Of The Topic	Hours
I	Automobile Engines Basic Engine Components – Functions , types , materials and construction of –Cylinder block – Crankcase – oil pan - Cylinder head – Gaskets – cylinder liners– Comparison of liners – Piston – piston rings – types of compression rings and oil control rings – piston pin – Connecting rod - methods of connecting piston and Connecting rod – Crankshaft – flywheel – Cam shaft – Valve and Valve mechanism – L-I-F-T.Cooling systems – purpose – types –	14

	air and water cooling systems – merits and demerits –pump assisted water cooling systems –components – water pump, fan - thermostat – types - radiator –types –pressure cap - troubles in cooling system. Lubrication systems – purpose – types of lubricants – additives – Service rating of oil – types of lubricating systems - Full pressure system – techniques of cylinder and piston lubrication – oil filters – full flow and bypass filter systems - Troubles in lubrication system.	
II	<p>Fuel Feed Systems And Alternative fuels</p> <p>Requirements of good fuel-Types of fuel feed systems- S.U. Electrical fuel pump – fuel filter – Air cleaners – types- petrol injection –merits and demerits – DTSI – VTI – CCVTI – PGMFI – MPFI system. Layout of diesel and petrol fuel feed system – single acting fuel feed pump – fuel injection pumps – Construction and working of distributor type pump – CRDI system - fuel injectors – types – Single & Multi hole – pintle and pintaux - fuel filters – primary and secondary filters.</p> <p>Alcohol, Hydrogen, Compressed Natural Gas, Liquefied Petroleum Gas and Bio Diesel - Properties, Suitability, Merits and Demerits - Engine Modifications</p>	<p>12</p> <p>3</p>
III	<p>Transmission And Power Trains</p> <p>General arrangement of power transmission system – Arrangement of front engine rear drive – rear engine rear drive – front engine front drive - four wheel drive – applications – clutch – function – Components – Types - Single plate ,multi plate and diaphragm spring clutch – fluid coupling – Clutch troubles and their causes.</p> <p>Gear box – purpose – various resistance to motion – types of gear boxes –constant mesh and synchromesh-gear box troubles and their causes.</p> <p>Drive line – propeller shaft – Universal joint – Cross type only – slip joint – final drive – function – types of gear arrangement – straight & spiral Bevel , Hypoid ,Worm and Worm Wheel – merits , demerits</p>	<p>5</p> <p>3</p> <p>7</p>

	and application – Hotch kiss drive –Torque tube drive – radius rod. Differential – purpose – Construction and operation – Self locking and non slip differential – Differential troubles and their Causes – Semi floating, three quarter floating and full floating rear axles.	
IV	<p>Automobile Chassis</p> <p>Front axle – Types – Stub axle – Types – Steering system – Ackermann Principle of Steering – Wheel alignment – Factors – Camber , Caster , King pin inclination , Toe in and Toe out on turns - Steering linkages – Steering gears –Cam and double roller ,recirculating ball type , Rack and Pinion – Steering troubles and causes – power steering – Necessity – types – Layout of any one type – Collapsible Steering system.</p> <p>Suspension system – Functions – Type of springs – Leaf , coil and Torsion bar– Front suspension systems – independent front suspension –merits and demerits – types – rear end suspension – Air suspension - shock absorber –purpose – telescopic type – construction and working.</p> <p>Brake system – functions – classification of brakes – drum brakes – leading shoe and trailing shoe – Self energizing action – hydraulic brake – brake bleeding - Air assisted hydraulic brakes – Air brake – layout , functions of each component and application only – disc brakes – construction and working – comparison of disc and drum type – brake troubles and their causes – anti lock Brake system.</p> <p>Wheels – types of wheels – brief description and applications – tyres – function– construction of tyres – cross and radial ply tyres – comparison.</p>	<p>7</p> <p>3</p> <p>3</p> <p>2</p>

V	Electrical Equipment & Hybrid Electric Vehicles	
	Battery – lead acid battery – Nickel alkaline battery – construction – battery rating – charging - testing – starting circuit - construction and operation of starter motor – starting motor drives – over running clutch and Bendix drive – construction and operation – solenoid switch - Charging circuit – alternator construction and operation – regulators – Dynamo.	6
	Ignition system – Types – High tension magneto – electronic ignition – Ignition system troubles and remedies. Lighting system – circuit – Head light – Aiming and adjustment – sealed beam head lights – directional signal circuits – fluorescent lamp - Horn circuits – Wind screen wiper.	5
	Introduction: Concept and environmental importance of EVs, HEVs and solar vehicles. Electric vehicles: Layout, construction and working. Hybrid electric vehicles: Types, layout, hybridization factor, plug in hybrid electric vehicles, fuel efficiency analysis. Challenges and future scope of EVs and HEVs. EMISSION STANDARDS: Euro I, II, III and IV norms, Bharat Stage II, III, IV norms. Motor Vehicle Act.	4

Reference Books:

1. Automobile Engineering, G.B.S.Narang, Khanna Publishers, NewDelhi.
2. AutomotiveMechanics,William H.crouse and Donald .L. Anglin, Tata McGraw– Hill Publishing CompanyLtd, NewDelhi.
3. The Automobile, Harbans Singh Reyat, S.Chand &Co Ltd, NewDelhi
4. Vehicle and Engine technology. Vol. I,HeinzHeisler, , ELBS
5. Automotive Mechanics,Joseph Heitner, East–west Press (P) Ltd, NewDelhi
6. Internal Combustion engines, M.L.Mathur &R.P.Sharma, Dhanpat Rai & Sons,
7. Modern Electric, Hybrid Electric and Fuel Cell Vehicles, Mehrdad Ehsani, Yimin Gao, Sebastien E.Gay, Ali Emadi, CR Press, London, New York
8. Electric & hybrid Vehicle, A.K.babu, Khanna Publications, New delhi.

Blank Page

STATE BOARD OF TECHNICAL EDUCATION & TRAINING, TAMILNADU
DIPLOMA IN ENGINEERING / TECHNOLOGY SYLLABUS
N - SCHEME

(To be implemented for the students admitted from the year 2020 - 2021 onwards)

Course Name : 1020 Diploma in Mechanical Engineering
 Subject Code : 4020640
 Semester : VI
 Subject Title : Solid Modelling Practical

TEACHING AND SCHEME OF EXAMINATION

No of weeks per semester: 16 weeks

Subject	Instructions		Examination			
	Hours / Week	Hours / Semester	Marks			Duration
Internal Assessment			Board Examinations	Total		
4020640 Solid Modelling Practical	6	96	25	100*	100	3 Hrs.

* Examinations will be conducted for 100 marks and it will be reduced to 75 marks for result.

RATIONALE:

A Mechanical Engineering Diploma Engineer is expected to possess a thorough understanding of drawing, which includes clear visualization and proficiency in reading and interpreting a wide variety of production drawing. The market driven economy demands frequent changes in product design to suit the customer requirements. The introduction of this subject is to provide hands on experience in sketching and modeling of the industrial components using any one of the Computer Aided Design and Modelling packages. The aim of this subject is to help the student to attain the industry identified competency through practice in CAD software.

OBJECTIVES:

- Prepare 2D Drawing using sketcher or part modelling of any parametric CAD software.
- Generate 3D Solid models from 2D sketch or part modelling of any parametric CAD software.
- Prepare assembly of part models using assembly of any parametric CAD software.
- Generate orthographic views of 3D solid models/assemblies using drafting of any parametric software.
- Plot a drawing for given part model/assembly.

DETAILED SYLLABUS

Contents: Practical

Introduction

Parametric CAD software – sketch – elements – entities: line – circle – arc – ellipse – polygon – text – dimensions – sketch tools – fillet – chamfer – offset – trim – extend – mirror – rotate – block. Partmodelling– reference planes – reference point – reference axes – co-ordinate system – extrude – revolve – swept – helix and spiral – lofts – dome – shell – draft – rib – wrap – intersect – holes – patterns. Assembly – approaches – mate – coincident – sub assembly –rebuild – isolate. Drawing views – Save – Plot – model view – exploded view – projected view – section view – import – export – Appearance – rendering.

Exercises

PART A: Draw the given 3D drawing using 3D modelling commands.

1. Model 1
2. Model 2
3. Model 3
4. Model 4
5. Model 5
6. Model 6

PART B: Draw the part models and assemble the components using 3D modelling.

1. Revolving Centre

2. Tail stock
3. Machine Vice
4. Crane hook
5. Petrol Engine Connecting Rod
6. Pipe Vice

Board Examination

Note: All the exercises should be completed All the exercises should be given for examination, the students are permitted to select by lot or the question paper from DOTE should be followed. Record note book should be submitted during examination.

Two exercises will be given for examination by selecting one exercise in each PART. The printout of exercises of the student work should be submitted with answer paper and the same have to be evaluated as per the allocation.

DETAILED ALLOCATION OF MARKS

Sl. No.	Performance Indicator	Marks
Part A – 3D Component Modelling		
1	Sketching	15
2	3D Modelling	15
Part B – Assemble Drawing Modelling		
3	Sketching / Part modelling	20
4	Assembly	30
5	Solid Model / Views	10
6	Viva voce	10
Total		100

LIST OF EQUIPMENTS

- Personal computer : 30 Nos.
- Laser Printer : 1 No.
- Software : GUI System Software
: Modelling package – Sufficient to the strength.

Blank Page

STATE BOARD OF TECHNICAL EDUCATION & TRAINING, TAMILNADU
DIPLOMA IN ENGINEERING / TECHNOLOGY SYLLABUS
N – SCHEME

(To be implemented for the students admitted from the year 2020 – 2021 onwards)

Course Name : 1020 Diploma in Mechanical Engineering
 Subject Code : 4020651
 Semester : VI
 Subject Title : Industrial Robotics and 3D Printing Practical

TEACHING AND SCHEME OF EXAMINATION

No of weeks per semester: 16 weeks

Subject	Instructions		Examination			Duration
	Hours / Week	Hours / Semester	Marks			
Internal Assessment			Board Examinations	Total		
4020651 Industrial Robotics and 3D Printing Practical	5	80	25	100*	100	3 Hrs.

* Examinations will be conducted for 100 marks and it will be reduced to 75 marks for result.

Objectives

- Study of Robot / Study of robot simulation software
- To study the components required.
- To study the techniques of programming for various industrial manufacturing applications.
- Prepare a record of work done.
- Acquire knowledge in the field of Additive Manufacturing
- Explain the various concepts of Solid Modelling
- Create STL files to manufacture components using 3D Printer

4020651 INDUSTRIAL ROBOTICS AND 3D PRINTING PRACTICAL DETAILED SYLLABUS

Contents:

3D Printing : Getting to know the User Interface of the Modelling software – Home Screen – Navigating the main Screen – Options Bar – Application Menu & Quick Access Toolbar – Describe the function of a sketch - Describe the various types of sketches. Create sketches of 3D models. Basic Modelling Considerations – Describe part creation within the design process. Add placed features to existing parts. Create complex shapes by sweeping or lofting profiles. Assemblies - Managing the assemblies - Assemble a mechanical piece of equipment using constraints. STL files – introduction – conversion of parts from other file formats to STL file – Additive Manufacturing – types of 3D Printers – orientation and positioning of parts - producing 3D working models using 3D Printers.

Exercises

PART A - Robot Programming

1. Position recording using Cartesian co-ordinate system - (No. of positions - 9)
2. Position recording using Polar co-ordinate system - (No. of positions - 9)
3. Pick and place the objects - No. of objects - 6)
4. Pick and stack the objects - (No. of objects - 6)
5. Spray painting practice - (Area - 300mm x 300mm)
6. Spot welding practice - (No. of spots - 9)
7. Arc welding practice – (Length of weld 50 mm)
8. Assembling practice - (Minimum 3 Components)
9. Profile cutting practice - (Complicated profile – combination of lines and arcs)

PART B - 3D Printing

1. Create the model and produce the Gear Train in 3D printing.
2. Create the model and produce the Geneva Gear & Ratchet mechanism.

3. Create the model and produce the Slide-crank mechanism.

Note: Every student is asked to design and produce only one component of an assembly. After the completion of the product, individual parts are checked for its precision and matting in the assembly. Hence group exercises can be given. The models can be scaled according to the print area of the 3D Printer.

Board Examination

Note: All the exercises should be completed All the exercises should be given for examination, the students are permitted to select by lot or the question paper from DOTE should be followed. Record note book should be submitted during examination.

Two exercises will be given for examination by selecting one exercise in each PART.

DETAILED ALLOCATION OF MARKS

Sl. No.	Performance Indicator	Marks
Part A – Robot Programming		
1	Robot Program	20
2	Simulate / Execution	30
3	Result	10
Part B – 3D Prinitng		
4	CAD - Modelling	15
5	3D Printing	15
6	Viva voce	10
Total		100

LIST OF EQUIPMENTS (For 30 students)

Personal computer : 10 Nos.
6 Axis Robot : 1 No.
3D Printer : 1 No.
Software : GUI System Software
: Modelling package / 3D Printer
Sufficient to the strength.

Blank Page

STATE BOARD OF TECHNICAL EDUCATION & TRAINING, TAMILNADU
DIPLOMA IN ENGINEERING / TECHNOLOGY SYLLABUS
N - SCHEME

(To be implemented for the students admitted from the year 2020 - 2021 onwards)

Course Name : 1020 Diploma in Mechanical Engineering
 Subject Code : 4020652
 Semester : VI
 Subject Title : Refrigeration and Air-Conditioning Practical

TEACHING AND SCHEME OF EXAMINATION

No of weeks per semester: 16 weeks

Subject	Instructions		Examination			Duration
	Hours / Week	Hours / Semester	Marks			
Internal Assessment			Board Examinations	Total		
4020652 Refrigeration and Air-Conditioning Practical	5	80	25	100*	100	3 Hrs.

* Examinations will be conducted for 100 marks and it will be reduced to 75 marks for result.

OBJECTIVES:

- Identify the various tools used in R & AC
- Demonstrate the construction and working of window air conditioner
- Demonstrate the construction and working of split type air conditioner
- Set parameters for comfortable operation of an air conditioner.
- Determine the C.O.P of air conditioner.
- Determine the capacity of window air conditioner.
- Describe the wiring of refrigerator and coolers.
- Perform servicing on air conditioner.

Experiments:

PART A

1. Determine the refrigerating effect, C.O.P and the compressor capacity of a open type system with any one expansion device. (Thermostatic expansion valve / Capillary tube / Automatic Expansion Valve)
2. Determine the C.O.P of sealed system by using electrical measurements.
3. Determine the capacity of a window air conditioner.
4. Determine the efficiency of a cooling tower.
5. Conduct Leak tests in a split air conditioning system, detect the failures and suggest the remedies. Conduct the Refrigerant Charge Test.
6. Conduct the flush test to remove the contaminants of refrigeration system and recharge.

PART- B

1. Study the various sizes of copper and steel tubing. To study the various tools used for operations.
2. Study and carry out the various operations on copper and steel tubing– Flaring, Swaging and Soldering methods used in R& A.C.
3. Study the methods to set and adjust the following a) Thermostats, b) Low pressure and high pressure cut-outs c) Thermostatic expansion valve d) Automatic Expansion Valve.
4. Conduct the service to change refrigerant into service cylinder from storage cylinder.
5. Conduct the service to pump down the system and to purge air from the system.
6. Conduct the service to check the oil level in the compressor and trace the common faults in R & A.C units and their remedies.

BOARD EXAMINATION

Note:

1. All the experiments in both sections should be completed. Two experiments will be given for examination by selecting one from PART A and one from PART B.
2. All the experiments should be given in the question paper and students are allowed to select by a lot or Question paper issued from the DOTE should be followed.
3. All regular students appearing for first attempt should submit record notebook for the examination.
4. The external examiner should verify the availability of the facility for the batch strength before commencement of practical examination.
5. The external examiner should verify the working condition of machinery's / equipment before commencement of practical examination.

Detailed Allocation of Marks

PART A

Procedure	-	10
Formulae / Observation	-	20
Calculation / Result	-	20

PART B

Description / Procedure	-	15
Tool handling	-	15
Conclusion / Report	-	10

Viva voce - 10

TOTAL - 100

LIST OF EQUIPMENTS (For 30 students)

WORKING MODELS OF THE FOLLOWING WITH ARRANGEMENTS FOR CONDUCTING TESTS

1. Refrigerator with test rig
2. Water cooler
3. Window A/C with test rig
4. Split A/C
5. Cooling tower

WORKING MODEL OF THE FOLLOWING TO CONDUCT EXPERIMENTS

1. Thermostat units
2. Cut off units
3. Thermostatic expansion valve unit
4. Automatic expansion valve unit
5. Sealed compressor with experimental setup

TOOLS:

1. Mechanics tool set
2. Tube cutter
3. Tube bender type
4. Tube bender spring
5. Swaging tool
6. Flaring block
7. Flaring nut
8. Pinching tool
9. Capillary tube testing gauge
10. Blow Lamp

SERVICE TOOLS:

1. Gas cylinder with receiver valve and key
2. Charging System
3. Blow lamp
4. Stem key
5. Spring remover
6. Service valve
7. 't' connector
8. High pressure gauge
9. Compound gauge
10. Leak detector
11. Soldering and Brazing kit.

STATE BOARD OF TECHNICAL EDUCATION & TRAINING, TAMILNADU
DIPLOMA IN ENGINEERING / TECHNOLOGY SYLLABUS
N – SCHEME

(To be implemented for the students admitted from the year 2020 – 2021 onwards)

Course Name : 1020 Diploma in Mechanical Engineering

Subject Code : 4020653

Semester : VI

Subject Title : Automobile Technology Practical

TEACHING AND SCHEME OF EXAMINATION

No of weeks per semester: 16 weeks

Subject	Instructions		Examination			
	Hours / Week	Hours / Semester	Marks			Duration
Internal Assessment			Board Examinations	Total		
4020653 Automobile Technology Practical	5	80	25	100*	100	3 Hrs.

* Examinations will be conducted for 100 marks and it will be reduced to 75 marks for result.

OBJECTIVES:

- Identify the various tools and their applications used in Automobile.
- Dismantle and assemble parts of petrol engine.
- Dismantle and assemble parts of diesel engine.
- Service AC fuel pump, oil pump and water pump.
- Dismantle and assemble fuel injection pump..
- Dismantle and assemble steering gear box.
- Testing and charging of batteries.
- Overhauling of starter motor, alternator.
- Troubleshoot the electrical circuits in automobile.

Exercises

PART-A

1. Dismantling and assembling of four stroke petrol engine and identification of parts.
2. Removing camshaft, replacing timing gears, removing valves, lapping and adjusting valve clearance.
3. Removing, servicing and replacing of fuel pump, oil pump & water pump.
4. Removing, servicing & replacing MPFI system.
5. Dismantling and assembling of inline fuel injection pump / CRDI system.
6. Test a battery with specific gravity test and charge the battery with constant amperage / voltage method.

PART-B

1. Removing and replacing of pressure plate and clutch plate, fingers adjustment
2. Dismantling, inspecting and assembling of constant mesh gear box and find out the gear ratios.
3. Dismantling, assembling and adjusting of steering gear box.
4. Dismantling, overhauling and assembling of starter motor / alternator
5. Trace the automobile electrical system with respect to battery coil ignition system
6. Trace the automobile electrical system with respect to (i) horn relay circuit, (ii) Wiper circuit & explain with neat circuit diagram.

BOARD EXAMINATION

Note:

1. All the exercises in both sections should be completed. Two exercises will be given for examination by selecting one from PART A and one from PART B.
2. All the exercises should be given in the question paper and students are allowed to select by a lot or question paper issued from the DOTE should be followed.
3. All regular students appearing for first attempt should submit record notebook for the examination.
4. The external examiner should verify the availability of the facility for the batch strength before commencement of practical examination.
5. The external examiner should verify the working condition of machinery's / equipment before commencement of practical examination.

Detailed Allocation of Marks

PART A

Dismantling Procedure	-	20
Tools handling methods	-	15
Assembly / Report	-	10

PART B

Dismantling Procedure	-	20
Tools handling methods	-	15
Assembly / Report	-	10

Viva voce - 10

TOTAL - 100

LIST OF EQUIPMENTS (Sufficient for 30 students)

1. Automobile Mechanic's tools-Complete Set
2. Internal circlip plier, bearing puller
3. Feeler gauge to check valve clearance, hammer and accessories
4. Compressor to supply high pressure air to clean oil and water filters.
5. 4 stroke petrol engine - with all accessories
6. 4 stroke Diesel engine - with all accessories
7. Engine cylinder with liner and cylinder bore dial gauge
8. Oil pump and water pump.
9. MPFI.
10. Inline Fuel Injection Pump
11. CRDI
12. Injectors.
13. Clutch set arrangement with tools
14. Complete gear box with tools
15. Complete steering arrangement
16. Battery and charging set up.
17. Measuring instruments
18. Consumables

STATE BOARD OF TECHNICAL EDUCATION & TRAINING, TAMILNADU
DIPLOMA IN ENGINEERING / TECHNOLOGY SYLLABUS
N - SCHEME

(To be implemented for the students admitted from the year 2020 - 2021 onwards)

Course Name : 1020 Diploma in Mechanical Engineering
 Subject Code : 4020660
 Semester : VI
 Subject Title : Project Work and Internship

TEACHING AND SCHEME OF EXAMINATION

No of weeks per semester: 16 weeks

Subject	Instructions		Examination			
	Hours / Week	Hours / Semester	Marks			Duration
Internal Assessment			Board Examinations	Total		
4020660 Project Work and Internship	6	96	25	100*	100	3 Hrs.

* Examinations will be conducted for 100 marks and it will be reduced to 75 marks for result.

RATIONALE: This subject ‘Project Work and Internship’ is the continuation of the previous semester subjects. The students are to implement the detailed project plan, which they have prepared. This project are generally an integration of the various types of skills acquired during their course of study. Hence it is essential that students are given opportunity to develop and integrate the highly essential industry oriented competencies and skills. This subject build up greater confidence to face in the world of work.

OBJECTIVES:

- Implement the theoretical and practical knowledge gained through the curriculum into an application suitable for a real practical working environment preferably in an industrial environment.
- Implement the planned activity as a team.
- Take appropriate decisions on collected information.

- Carryout cooperative learning through synchronous guided discussions within the class in key dates, asynchronous document sharing and discussions, as well as to prepare collaborative edition of the final project report.

Project Work and Internship:

The students of all the Diploma Courses have to do a Project Work as part of the Curriculum and in partial fulfillment for the award of Diploma by the State Board of Technical Education and Training, Tamil Nadu. In order to encourage students to do worthwhile and innovative projects, every year prizes are awarded for the best three projects i.e. institution wise, region wise and state wise. **The Project work must be reviewed twice in the same semester. The project work is approved during the V semester by the properly constituted committee with guidelines.**

a) Internal assessment mark for Project Work and Internship:

Project Review I	...	10 marks
Project Review II	...	10 marks
Attendance	...	05 marks (Award of marks same as theory subject pattern)
<hr/>		
Total	...	25 marks

Proper record should be maintained for the two Project Reviews and preserved for one semester after the publication of Board Exams results. It should be produced to the flying squad and the inspection team at the time of inspection/verification.

b) Allocation of Marks for Project Work and Internship in Board Examinations:

Demonstration/Presentation	25 marks
Report	25 marks
Viva Voce	30 marks
Internship Report	20 marks
<hr/>	
Total	100* marks

*Examination will be conducted for 100 marks and will be converted to 75 marks.

c) Internship Report:

The internship training for a period of two weeks shall be undergone by every candidate at the end of IV / V semester during vacation. The certificate shall be produced along with the internship report for evaluation. The evaluation of internship training shall be done along with final year “Project Work & Internship” for 20 marks. The internship shall be undertaken in any industry / Government or Private certified agencies which are in social sector / Govt. Skill Centres / Institutions / Schemes.

A neatly prepared PROJECT REPORT as per the format has to be submitted by individual student during the Project Work and Internship Board examination.

SANDWICH DIPLOMA COURSE - INDUSTRIAL TRAINING

4020480 Industrial Training I

4020720 Industrial Training II

1. Introduction

The main objective of the sandwich Diploma course is to mould a well-rounded technician acclimated with industrial environment while being a student in the institution.

The Sandwich Diploma Course study is pursued by students, in 7 Semesters of 3 ½ years duration, the subjects of 3years-Full Time Diploma Course being regrouped for academic convenience.

While in the 4th semester students under Industrial Training for 6 months (December through May). They also do course work in the institution for one day in a week, While in the 7th semester they undergo another spell of 6 months (June through November) Industrial training.

The Apprenticeship (Amendment) Act 1973 is followed in regulating the Industrial training procedure for Sandwich Course.

I SEM	II SEM	III SEM	IV SEM	V SEM	VI SEM	VII SEM
-------	--------	---------	--------	-------	--------	---------

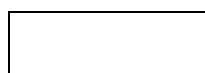

Institutional Training



Industrial Training

2. Attendance Certification

Every month students have to get their attendance certified by industrial supervisor in the prescribed form supplied to them. Students have also to put their signature on the form and submit it to the institution supervisor. Regularity in attendance and submission of report will be duly considered while awarding the Internal Assessment mark.

3. Training Reports

The students have to prepare two types of reports:

- Weekly report in the form of diary to be submitted to the concerned staff in-charge of the institution. This will be reviewed while awarding Internal Assessment marks.
- Comprehensive report at the end of each spell which will be used for Board Examination.

3.1 Industrial Training Diary

Students are required to maintain the record of day-to-day work done. Such record is called Industrial training Diary. Students have to write this report regularly. All days for the week should be accounted for clearly giving attendance particulars (Presence, absence, Leave, Holidays etc.). The concern Industrial supervisor is to check periodically these progress reports.

3.2 Comprehensive Training Report

In addition to the diary, students are required to submit a comprehensive report on training with details of the organisation where the training was undergone after attestation by the supervisors. The comprehensive report should be incorporating study of plant/product/process/construction along with intensive in-depth study on any one of the topics such as processes, methods, tooling, construction and equipment, highlighting aspects of quality, productivity and system. The comprehensive report should be completed in the last week of Industrial training. Any data, drawings etc. should be incorporated with the consent of the Organisation.

a. Scheme of Evaluation

1.1 Internal Assessment Marks

First Review (during 3 rd month)	: 10 marks
Second Review (during 5 th month)	: 10 marks
Attendance *	: 05 marks
	(Awarded same as in Theory)
Total	: 25 marks

1.2 Board Examination

Presentation about Industrial Training	: 20 marks
Comprehensive Training Report	: 30 marks
Viva-voce	: 25 marks
Total	: 75 marks

*** For awarding marks to attendance, the Industrial Training attendance has to be considered.**

STATE BOARD OF TECHNICAL EDUCATION & TRAINING, TAMILNADU
DIPLOMA IN ENGINEERING / TECHNOLOGY SYLLABUS
N - SCHEME

(To be implemented for the students admitted from the year 2020 - 2021 onwards)

Course Name : 2020 Diploma in Mechanical Engineering (Sandwich)
 Subject Code : 4020710
 Semester : VII
 Subject Title : Project Work

TEACHING AND SCHEME OF EXAMINATION

No of weeks per semester: 16 weeks

Subject	Instructions		Examination			
	Hours / Week	Hours / Semester	Marks			Duration
Internal Assessment			Board Examinations	Total		
4020710 Project Work	6	96	25	100*	100	3 Hrs.

* Examinations will be conducted for 100 marks and it will be reduced to 75 marks for result.

RATIONALE:

This subject 'Project Work' is the continuation of the previous semester subjects. The students are to implement the detailed project plan, which they have prepared. This project are generally an integration of the various types of skills acquired during their course of study. Hence it is essential that students are given opportunity to develop and integrate the highly essential industry oriented competencies and skills. This subject build up greater confidence to face in the world of work.

OBJECTIVES:

- Implement the theoretical and practical knowledge gained through the curriculum into an application suitable for a real practical working environment preferably in an industrial environment.
- Implement the planned activity as a team.
- Take appropriate decisions on collected information.

- Carryout cooperative learning through synchronous guided discussions within the class in key dates, asynchronous document sharing and discussions, as well as to prepare collaborative edition of the final project report.

Project Work:

The students of all the Diploma Courses have to do a Project Work as part of the Curriculum and in partial fulfillment for the award of Diploma by the State Board of Technical Education and Training, Tamil Nadu. In order to encourage students to do worthwhile and innovative projects, every year prizes are awarded for the best three projects i.e. institution wise, region wise and state wise. **The Project work must be reviewed twice in the same semester. The project work is approved during the V semester by the properly constituted committee with guidelines.**

a) Internal assessment mark for Project Work:

Project Review I	...	10 marks
Project Review II	...	10 marks
Attendance	...	05 marks (Award of marks same as theory subject pattern)
<hr/>		
Total	...	25 marks

Proper record should be maintained for the two Project Reviews and preserved for one semester after the publication of Board Exams results. It should be produced to the flying squad and the inspection team at the time of inspection/verification.

b) Allocation of Marks for Project Work and Internship in Board Examinations:

Demonstration/Presentation	40 marks
Project Report	30 marks
Viva Voce	30 marks
<hr/>	
Total	100* marks

*Examination will be conducted for 100 marks and will be converted to 75 marks.

A neatly prepared PROJECT REPORT as per the format has to be submitted by individual student during the Project Work Board examination.